

PART VOLUME: CU. IN.
PART WEIGHT: LBS.

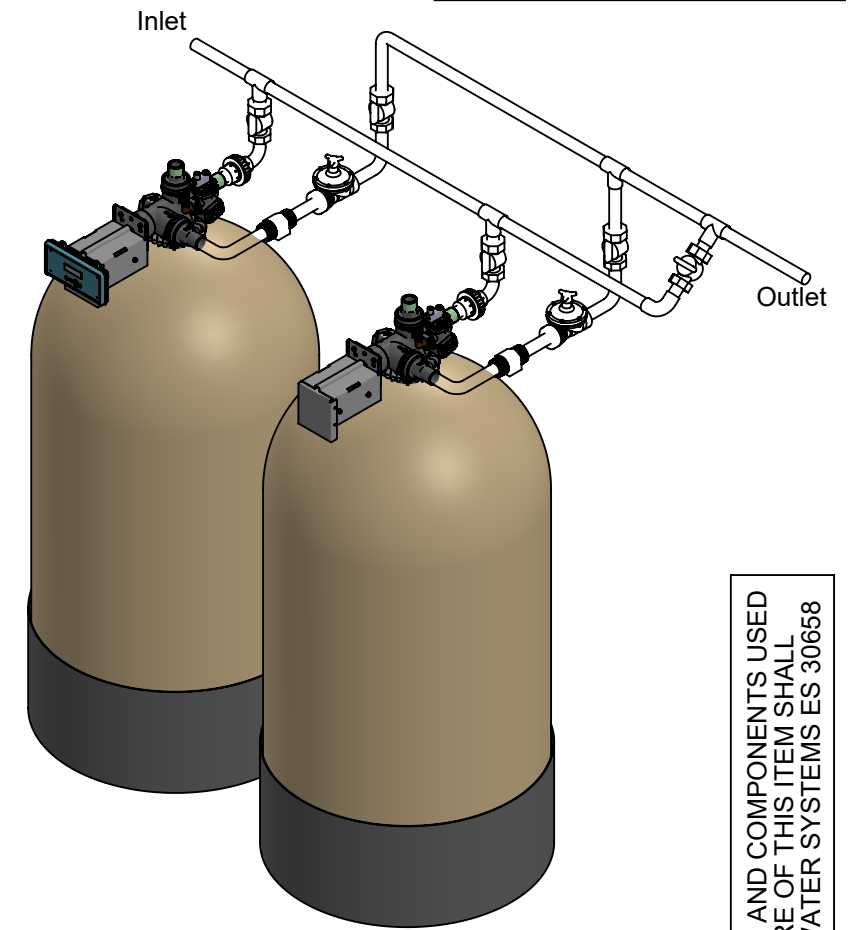
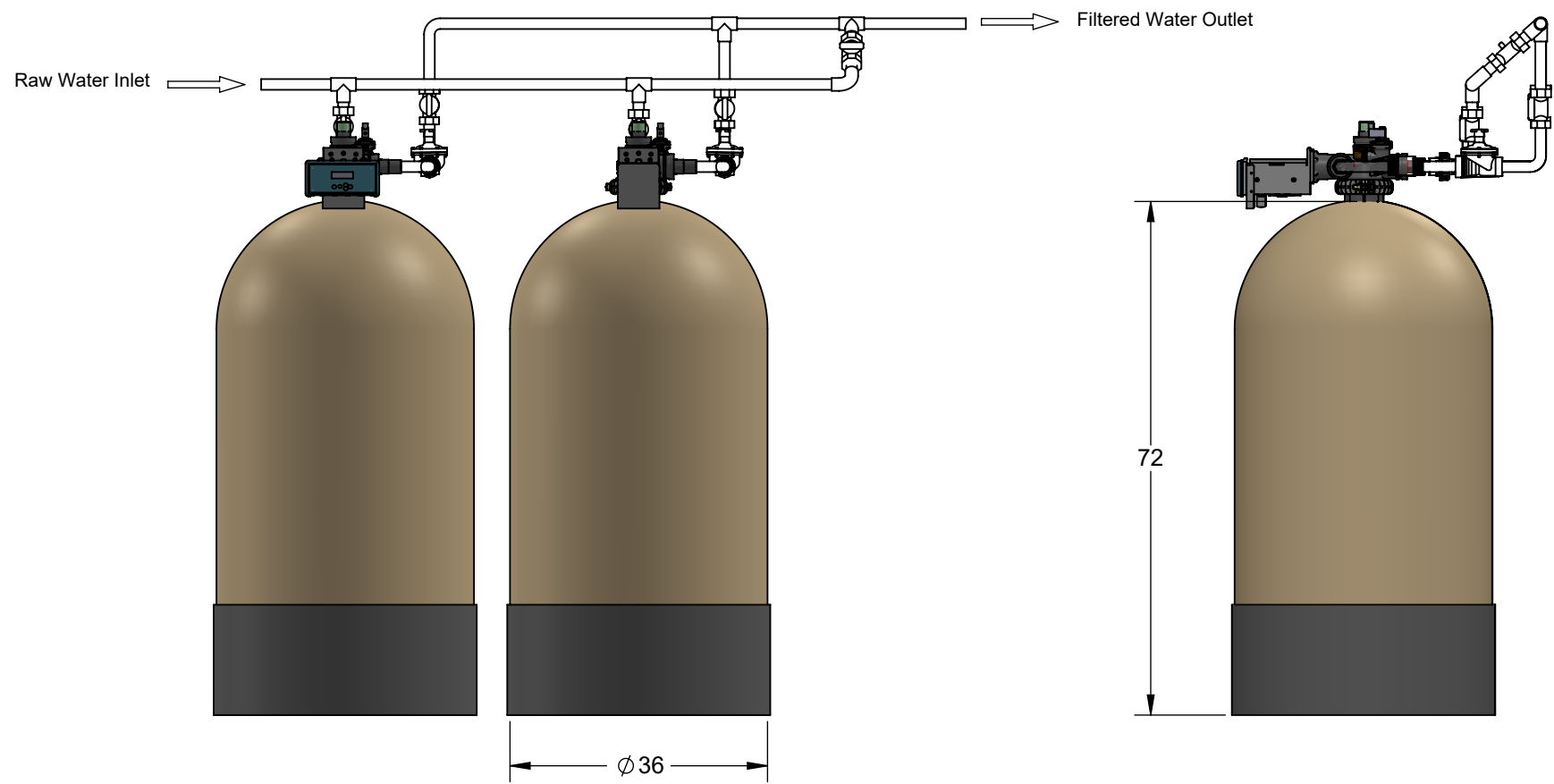
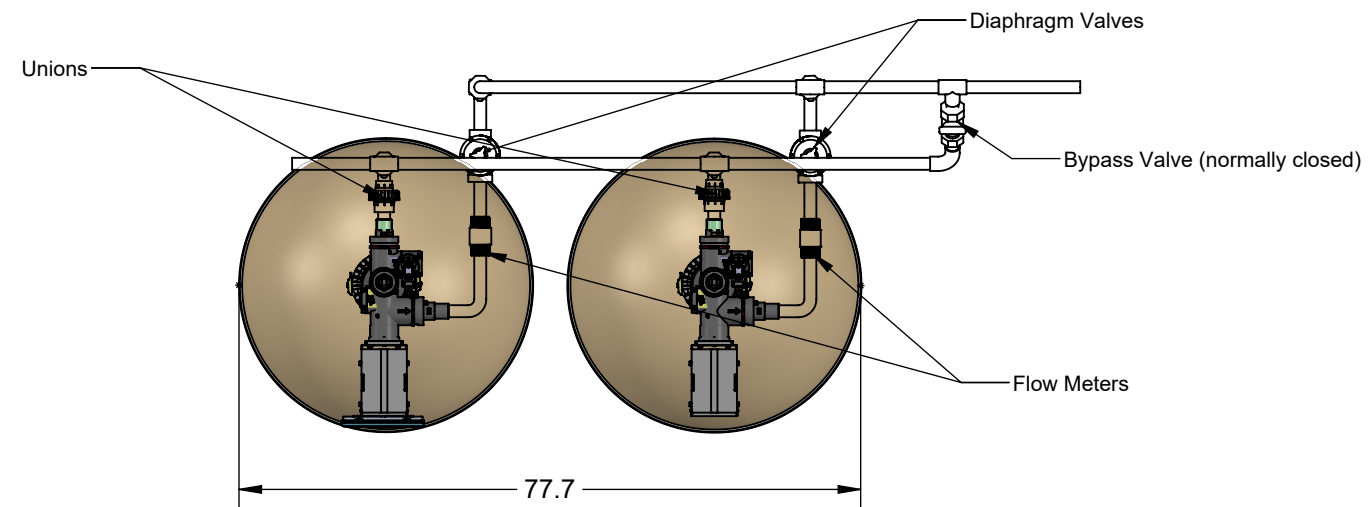

Notes:
All piping, fittings etc are provided by others
General plumbing connections are shown for clarity only
Mounting for electronic control will vary

ALL RAW MATERIALS AND COMPONENTS USED IN THE MANUFACTURE OF THIS ITEM SHALL COMPLY WITH ECOWATER SYSTEMS ES 30658

© 2014 ECOWATER SYSTEMS

UNLESS OTHERWISE SPECIFIED, ALL DIMENSIONS ARE IN INCHES
THIS PRINT, INCLUDING ALL INFORMATION SET FORTH THEREON, IS THE PROPERTY OF ECOWATER SYSTEMS AND IS LOANED IN CONFIDENCE SUBJECT TO RETURN UPON REQUEST AND WITH THE UNDERSTANDING THAT NO COPIES OF THIS PRINT OR OF THE INFORMATION SHALL BE MADE WITHOUT THE PRIOR WRITTEN CONSENT OF ECOWATER SYSTEMS. ALL RIGHTS TO DESIGN AND INVENTION ARE RESERVED.

DATE	APRV.	REV	EN. NO.	REVISION RECORD
		A		Release to production

PART NUMBER	MATL		SCALE 1:24	
	NEXT ASSMEBLY	REFERENCE	DRAWN BY	
	TOLERANCE UNLESS NOTED		CHK'D BY	
	ONE PLACE (.0) +/- .020		PROJ ENG	
	TWO PLACE (.00) +/- .010	ANGLES +/- 0° 30'	APPROVAL	
THREE PLACE (.000) +/- .005				
DO NOT SCALE DRAWING				

PART NAME		
SIZE	PART NUMBER	REV
B	PA362CD	