



NORTH STAR[™]
WATER TREATMENT SYSTEMS

Model NSCWHC

How to install, operate
and maintain your
Demand Controlled Water
Conditioner with Wi-Fi

If you have any questions or concerns when installing, operating or maintaining your water softener, contact us at:

info@northstarwater.com

or visit **www.northstarwater.com**

System tested and certified by NSF International against NSF/ANSI Standard 42 for the reduction of chlorine taste and odor, and Standard 44 for hardness reduction, efficiency and the reduction of barium and radium 226/228, and certified to NSF/ANSI/CAN Standard 372.



System tested and certified by the Water Quality Association against CSA B483.1.



Installation and Operation Manual



Designed, Engineered &
Assembled in the U.S.A.

Manufactured and warranted by
Water Channel Partners
1890 Woodlane Drive
Woodbury, MN 55125

7393658 (Rev. E 8/8/24)

TABLE OF CONTENTS

	<u>Page</u>
Specifications & Performance Claims	3-4
Before You Start	4
Inspect Shipment	5
Water Conditioning Information	5
Installation Requirements	6-7
Installation Instructions	8-13
Programming the Water Softener	14-16
Connecting the System to Wi-Fi	17-18
Controller Features	19-21
Routine Maintenance	22-23
Troubleshooting	24-26
Wiring Schematic	27
Optional Motorized Water Shutoff Valve	27
Exploded View & Parts List	28-31
Warranty	32

Dimensions

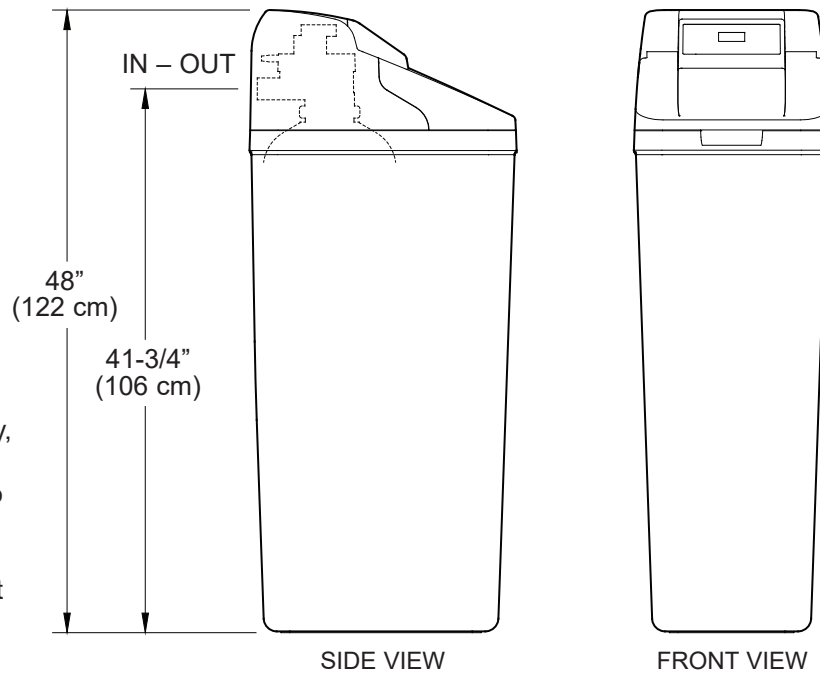
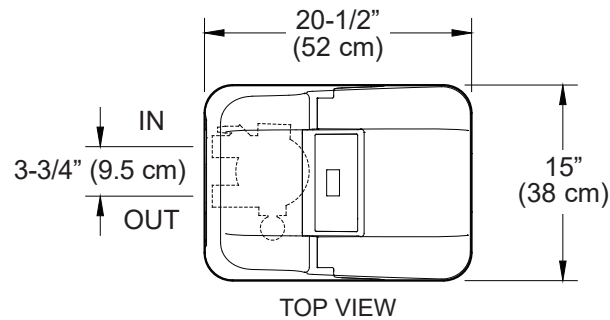

NOTE: Due to variances in production and assembly, the water softener valve height may vary by up to 1/2", and may not match previously installed systems. This will not affect system performance.

FIG. 1

Specifications & Performance Claims

This model is efficiency rated. The efficiency rating is valid only at the minimum salt dose. This system has a demand initiated regeneration (D.I.R.) feature that complies with specific performance specifications intended to minimize the amount of regenerant brine and water used in their operation.

This water treatment system has a rated softener efficiency of not less than 3,350 grains of total hardness exchange per pound of salt (based on sodium chloride) and shall not deliver more salt than its listed rating or be operated at a sustained maximum service flow rate greater than its listed rating. This system has been proven to deliver soft water for at least ten continuous minutes at the rated service flow rate. The rated salt efficiency is measured by laboratory tests described in NSF/ANSI Standard 44. These tests represent the maximum possible efficiency that the system can achieve. Operational efficiency is the actual efficiency after the system has been installed. It is typically less than the rated efficiency, due to individual application factors including water hardness, water usage, and other contaminants that reduce a softener's capacity.

While testing was performed under standard laboratory conditions, actual performance of the system may vary based on local water conditions. This system has been tested according to NSF/ANSI Standard 42 for the reduction of chlorine taste and odor. The concentration of the indicated substance in water entering the system was reduced to a concentration less than or equal to the permissible limit for water leaving the system, as specified in NSF/ANSI Standard 42.

SPECIFICATIONS	
Model NSCWHC	
Model Code	nHCP
Rated Softening Capacity (Grains @ Salt Dose)	11,000 @ 2.6 lbs. 24,700 @ 7.8 lbs. 31,100 @ 13.4 lbs.
Rated Efficiency (Grains/Pound of Salt @ Minimum Salt Dose)	4,230 @ 2.6 lbs.
Water Used During Regeneration @ Minimum Salt Dose	4.3 gal. / 1,000 grains
Total Water Used Per Regeneration @ Maximum Salt Dose	54.7 gallons
Rated Service Flow Rate	8.0 gpm
Amount of High Capacity Ion Exchange Resin	0.98 cu. ft.
Amount of Activated Carbon	0.25 cu. ft.
Amount of Gravel	10 lbs.
Pressure Drop at Rated Service Flow	8.4 psig
Intermittent Flow Rate @ 15 psi ①	11.5 gpm
Water Supply Max. Hardness	120 gpg
Water Supply Max. Clear Water Iron	3 ppm ②
Water Supply Pressure Limits (minimum / maximum)	20 - 125 psi (138 - 862 kPa) ③
Water Temperature Limits (minimum / maximum)	40 - 120 °F (5 - 49 °C)
Minimum Water Supply Flow Rate	3 gpm (11.4 lpm)
Maximum Drain Flow Rate	2.0 gpm (7.6 lpm)
Rated Capacity at Chlorine Concentration ④ of:	0.50 ppm 2,280,000 gal. (8,630,000 liters) ⑤ 0.75 ppm 1,520,000 gal. (5,750,000 liters) ⑤ 1.0 ppm 1,140,000 gal. (4,310,000 liters) ⑤ 1.5 ppm 760,000 gal. (2,870,000 liters) ⑤ 2.0 ppm 570,000 gal. (2,150,000 liters) ⑤

① Intermittent flow rate does not represent the maximum service flow rate used for determining the softener's rated capacity and efficiency. Continuous operation at flow rates greater than the service flow rate may affect capacity and efficiency performance.

② Capacity to reduce clear water iron is substantiated by laboratory test data. State of Wisconsin requires additional treatment if water supply contains clear water iron exceeding 5 ppm.

③ Canada working pressure limits: 1.4 - 7.0 kg/cm².

④ Typical residential chlorine concentration is 0.5 to 1.0 ppm.

⑤ From independent laboratory test data.

This system conforms to NSF/ANSI Standards 42 & 44 for the specific performance claims as verified and substantiated by test data.

continued on next page

Specifications & Performance Claims

continued from previous page

Variable Salt Dose: The salt dose is selected by the electronic controls at regeneration time based on the amount needed.

PERFORMANCE CLAIMS		
Contaminant	Influent Challenge Level	Maximum Allowable Product Water Level
Barium	10 ±10% mg/L	2.0 mg/L
Radium 226/228	25 pCi/L	5 pCi/L
Substance	Influent Challenge Level	Reduction Requirement
Chlorine	2.0 ±10% mg/L	50%

Before You Start

- The water softener requires a minimum water flow of 3 gallons per minute at the inlet. Maximum allowable inlet water pressure is 125 psi. If daytime pressure is over 80 psi, nighttime pressure may exceed the maximum. Use a pressure reducing valve if necessary (Adding a pressure reducing valve may reduce the flow). Failure to use a pressure reducing valve may cause damage to the system, resulting in flooding and damage to property. If your home is equipped with a back flow preventer, an expansion tank must be installed in accordance with local codes and laws.
- The water softener works on 24V DC electrical power, supplied by a direct plug-in power supply (included). Be sure to use the included power supply and plug it into a nominal 120V, 60 Hz household outlet that is in a dry location only, grounded and properly protected by an overcurrent device such as a circuit breaker or fuse.
- Do not use this system to treat water that is microbiologically unsafe or of unknown quality without adequate disinfection upstream or downstream of the system.



European Directive 2002/96/EC requires all electrical and electronic equipment to be disposed of according to Waste Electrical and Electronic Equipment (WEEE) requirements. This directive or similar laws are in place nationally and can vary from region to region. Please refer to your state and local laws for proper disposal of this equipment.

FCC NOTICE

NOTE: This equipment has been tested and found to comply with the limits for a Class B digital device, pursuant to Part 15 of the FCC Rules. These limits are designed to provide reasonable protection against harmful interference in a residential installation. This equipment generates, uses, and can radiate radio frequency energy and, if not installed and used in accordance with the instructions may cause harmful interference to radio communications.

However, there is no guarantee that interference will not occur in a particular installation. If this equipment does cause harmful interference to radio or television reception, which can be determined by turning the equipment off and on, the user is encouraged to try to correct the interference by one or more of the following measures:

- Reorient or relocate the receiving antenna.
- Increase the separation between the equipment and receiver.
- Connect the equipment into an outlet on a circuit different from that to which the receiver is connected.
- Consult the dealer or an experienced radio/TV technician for help.

IMPORTANT: Changes or modifications not expressly approved by the party responsible for compliance could void the user's authority to operate the equipment.

INDUSTRY CANADA NOTICE

This device complies with Industry Canada Standard RSS-210. Operation is subject to the following two conditions: (1) this device may not cause interference, and (2) this device must accept any interference, including interference that may cause undesired operation of the device.

Questions? Contact us at: info@northstarwater.com or visit www.northstarwater.com

Inspect Shipment

The parts required to assemble and install the unit are included in a bag. Thoroughly check the water softener for possible shipping damage and parts loss. Also inspect and note any damage to the shipping carton.

Remove and discard (or recycle) all packing materials. To avoid loss of small parts, we suggest you keep the small parts in the parts bag until you are ready to use them.

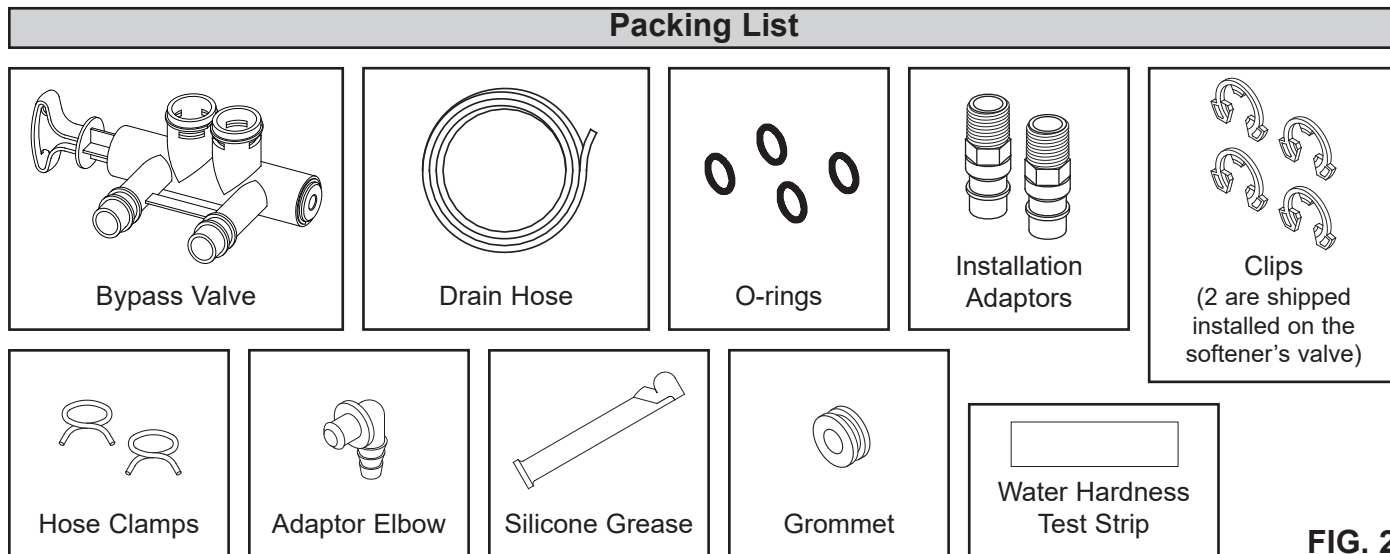

FIG. 2

Water Conditioning Information

IRON

Iron in water can cause stains on clothing and plumbing fixtures. It can negatively affect the taste of food, drinking water, and other beverages. Iron in water is measured in parts per million (ppm). The total* ppm of iron, and type or types*, is determined by chemical analysis. Four different types of iron in water are:

- Ferrous (clear water) iron
- Ferric (red water) iron
- Bacterial and organically bound iron
- Colloidal and inorganically bound iron (ferrous or ferric)

Ferrous (clear water) iron is soluble and dissolves in water. This water softener will reduce moderate amounts of this type of iron (see specifications).**

Ferrous (clear water) iron is usually detected by taking a sample of water in a clear bottle or glass.

Immediately after taking, the sample is clear. As the water sample stands, it gradually clouds and turns slightly yellow or brown as air oxidizes the iron. This usually occurs in 15 to 30 minutes.

When using the softener to reduce Ferrous (clear water) iron, add 5 grains to the hardness setting for every 1 ppm of Ferrous (clear water) iron. See "Set Water Hardness Number" section.

Ferric (red water), and bacterial and organically bound irons are insoluble. This water softener will not remove ferric or bacterial iron. This iron is visible

immediately when drawn from a faucet because it has oxidized before reaching the home. It appears as small cloudy yellow, orange, or reddish suspended particles. After the water stands for a period of time, the particles settle to the bottom of the container. Generally these irons are removed from water by filtration. Chlorination is also recommended for bacterial iron.

Colloidal and inorganically bound iron is of ferric or ferrous form that will not filter or exchange out of water. This water softener will not remove colloidal iron. In some instances, treatment may improve colloidal iron water. Colloidal iron water usually has a yellow appearance when drawn. After standing for several hours, the color persists and the iron does not settle, but remains suspended in the water.

SEDIMENT

Sediment is fine, foreign material particles suspended in water. This water softener will not remove sediment. This material is most often clay or silt. Extreme amounts of sediment may give the water a cloudy appearance. A sediment filter installed upstream of the water softener normally corrects this situation.

* Water may contain one or more of the four types of iron and any combination of these. Total iron is the sum of the contents.

** Capacity to reduce clear water iron is substantiated by laboratory test data.

Installation Requirements

LOCATION REQUIREMENTS

Consider all of the following when selecting an installation location for the water softener.

- Do not locate the water softener where freezing temperatures occur. Do not attempt to treat water over 120°F. Freezing temperatures or hot water damage voids the warranty.
- To condition all water in the home, install the water softener close to the water supply inlet, and upstream of all other plumbing connections, except outside water pipes. Outside faucets should remain on hard water to avoid wasting conditioned water and salt.
- A nearby drain is needed to carry away regeneration discharge (drain) water. Use a floor drain, laundry tub, sump, standpipe, or other options (check your local codes). See "Air Gap Requirements" and "Valve Drain Requirements" sections.
- The water softener works on 24V DC electrical power, supplied by a direct plug-in power supply (included). Provide nearby a 120V, 60Hz electrical outlet in accordance with NEC and local codes.
- Always install the water softener between the water inlet and water heater. Any other installed water conditioning equipment should be installed between the water inlet and water softener (See Figure 4 below).
- Avoid installing in direct sunlight. Excessive sun heat may cause distortion or other damage to non-metallic parts.

PLUMBING CODES

All plumbing must be completed in accordance with national, state and local plumbing codes.

In the state of Massachusetts: The Commonwealth of Massachusetts plumbing code 248-CMR shall be adhered to. A licensed plumber shall be used for this installation.

AIR GAP REQUIREMENTS

A drain is needed for the water discharged from the valve during the softener's regeneration cycle (See Figure 3). A floor drain, close to the water softener, is preferred. A laundry tub, standpipe, etc. are other drain options. Secure valve drain hose in place. Leave an air gap of 1-1/2" between the end of the hose and the drain. This gap is needed to prevent backflow of sewer water into the water softener. Do not put the end of the drain hose into the drain.

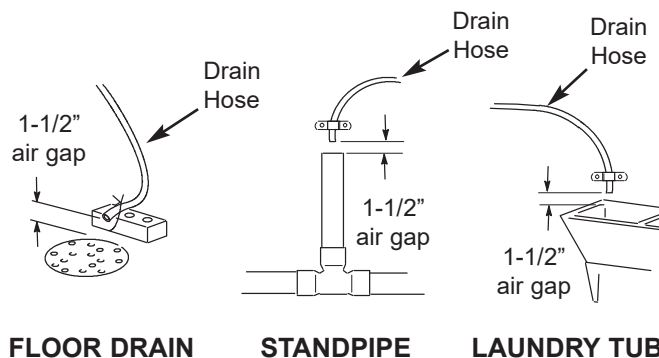

FIG. 3

THE PROPER ORDER TO INSTALL WATER TREATMENT EQUIPMENT

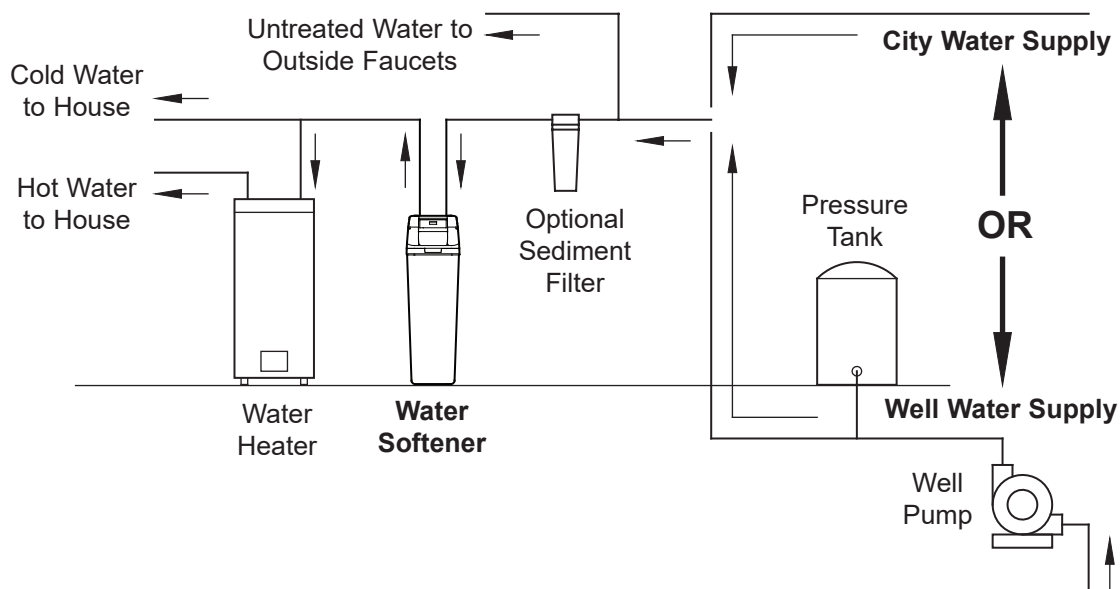

FIG. 4

Installation Requirements

VALVE DRAIN REQUIREMENTS

Using the flexible drain hose (included), measure and cut to the length needed. Flexible drain hose is not allowed in all localities (check your plumbing codes). If local codes do not allow use of a flexible drain hose, a rigid valve drain run must be used. Purchase a compression fitting (1/4 NPT x 1/2 in. minimum tube) and 1/2" tubing from your local hardware store. Plumb a rigid drain as needed (See Figure 6).

NOTE: Avoid drain hose runs longer than 30 feet. Avoid elevating the hose more than 8 feet above the floor. Make the valve drain line as short and direct as possible.

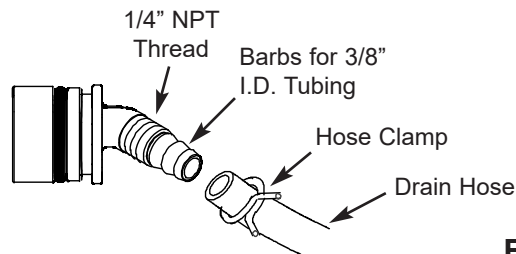

FIG. 5

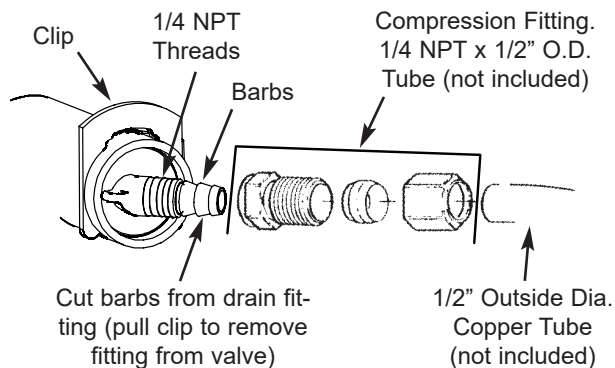

FIG. 6

INLET / OUTLET PLUMBING OPTIONS

Always install either a single bypass valve (provided), as shown in Figure 7, or, if desired, parts for a 3 valve bypass system (not included) can be purchased and assembled, as shown in Figure 8. Bypass valves allow you to turn off water to the softener for maintenance if needed, but still have water in house pipes.

Use:

- Copper pipe
- Threaded pipe
- PEX (Crosslinked Polyethylene) pipe
- CPVC plastic pipe
- Other pipe approved for use with potable water

IMPORTANT: Do not solder with plumbing attached to installation adaptors and single bypass valve. Soldering heat will damage the adaptors and valve.

SINGLE BYPASS VALVE

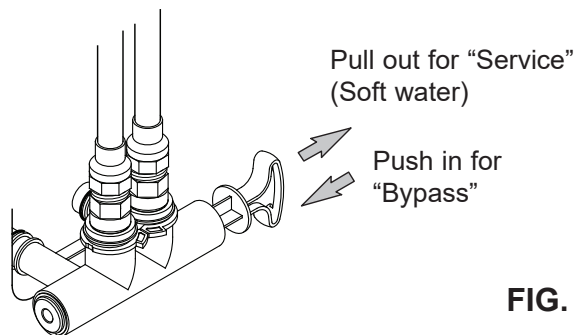

FIG. 7

3 VALVE BYPASS

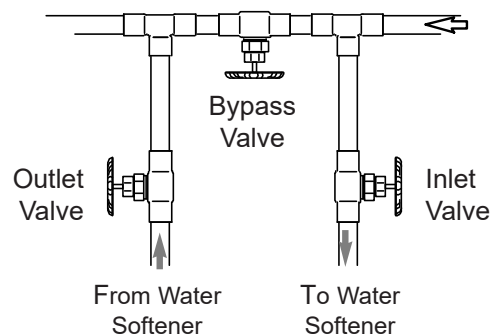

FIG. 8

Installation Instructions

TYPICAL INSTALLATION

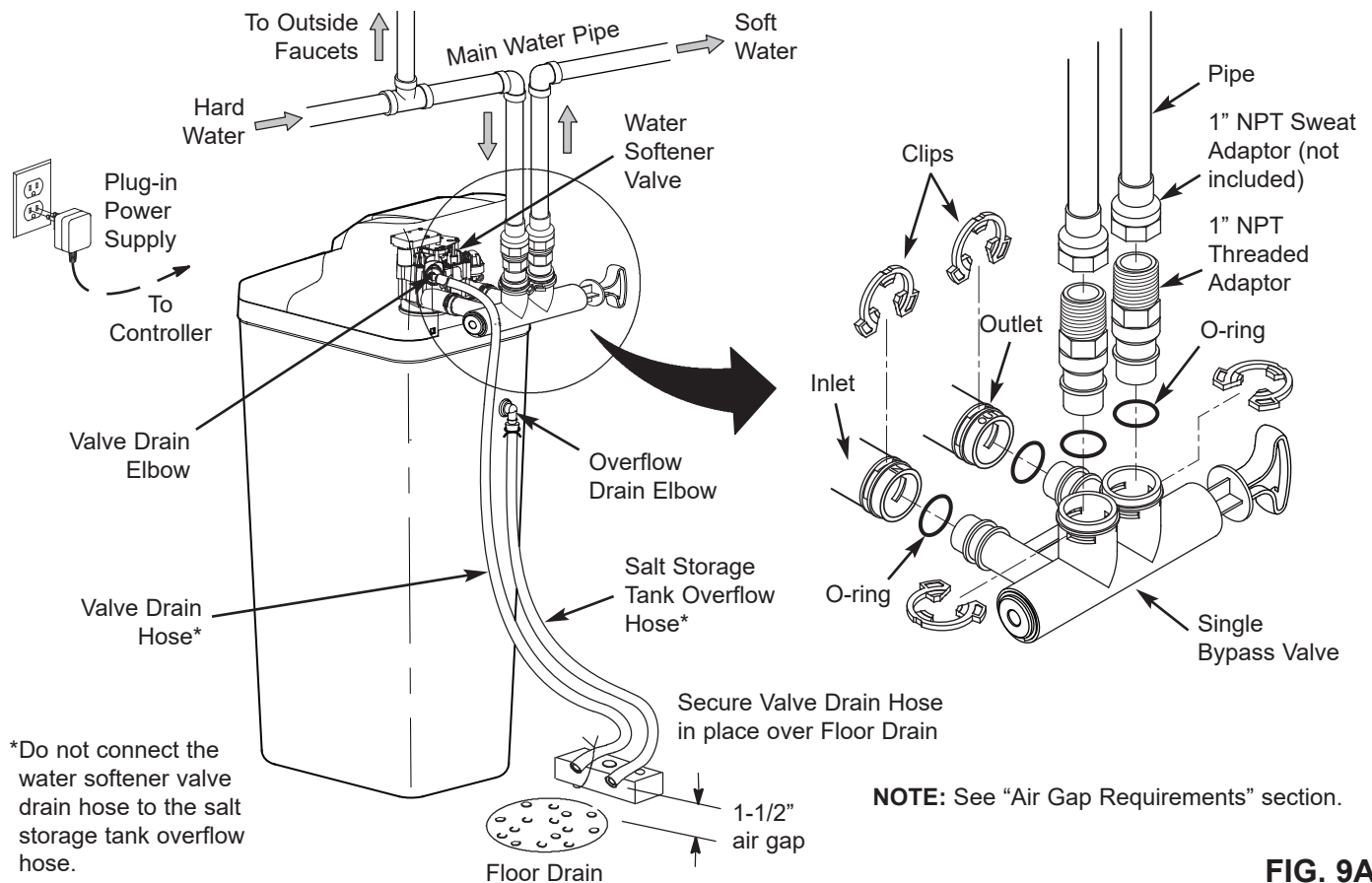

FIG. 9A

TURN OFF WATER SUPPLY

1. Close the main water supply valve, located near the well pump or water meter.
2. Shut off the electric or fuel supply to the water heater.
3. Open all faucets to drain all water from house pipes.

NOTE: Be sure not to drain water from the water heater, as damage to the water heater elements could result.

ASSEMBLY

1. North Star models are factory assembled. During installation, unsnap and remove the top cover, together with the salt lid (See Figure 11), to expose the softener valve assembly. Set them aside to prevent damage.
2. Install the brine tank overflow grommet and elbow into the 13/16" diameter hole in the back of the salt storage tank wall (See Figure 11).

MOVE THE UNIT INTO PLACE

1. Move the water softener into the desired location. Set it on a solid, level surface.

IMPORTANT: Do not place shims directly under the salt storage tank to level the softener. The weight of the tank, when full of water and salt, may cause the tank to fracture at the shim.

2. Visually check and remove any debris from the water softener valve inlet and outlet ports.
3. Make sure the turbine assembly spins freely in the "out" port of the valve (See Figure 10).
4. If not already done, put a light coating of silicone grease on the single bypass valve o-rings.
5. Push the single bypass valve into the softener valve as far as it will go. Snap the two large holding clips into place, from the top down as shown in Figures 12 & 13.

IMPORTANT: Be sure the clips snap firmly into place so the single bypass valve will not pull out.

Installation Instructions

TYPICAL INSTALLATION (with optional motorized water shutoff valve)

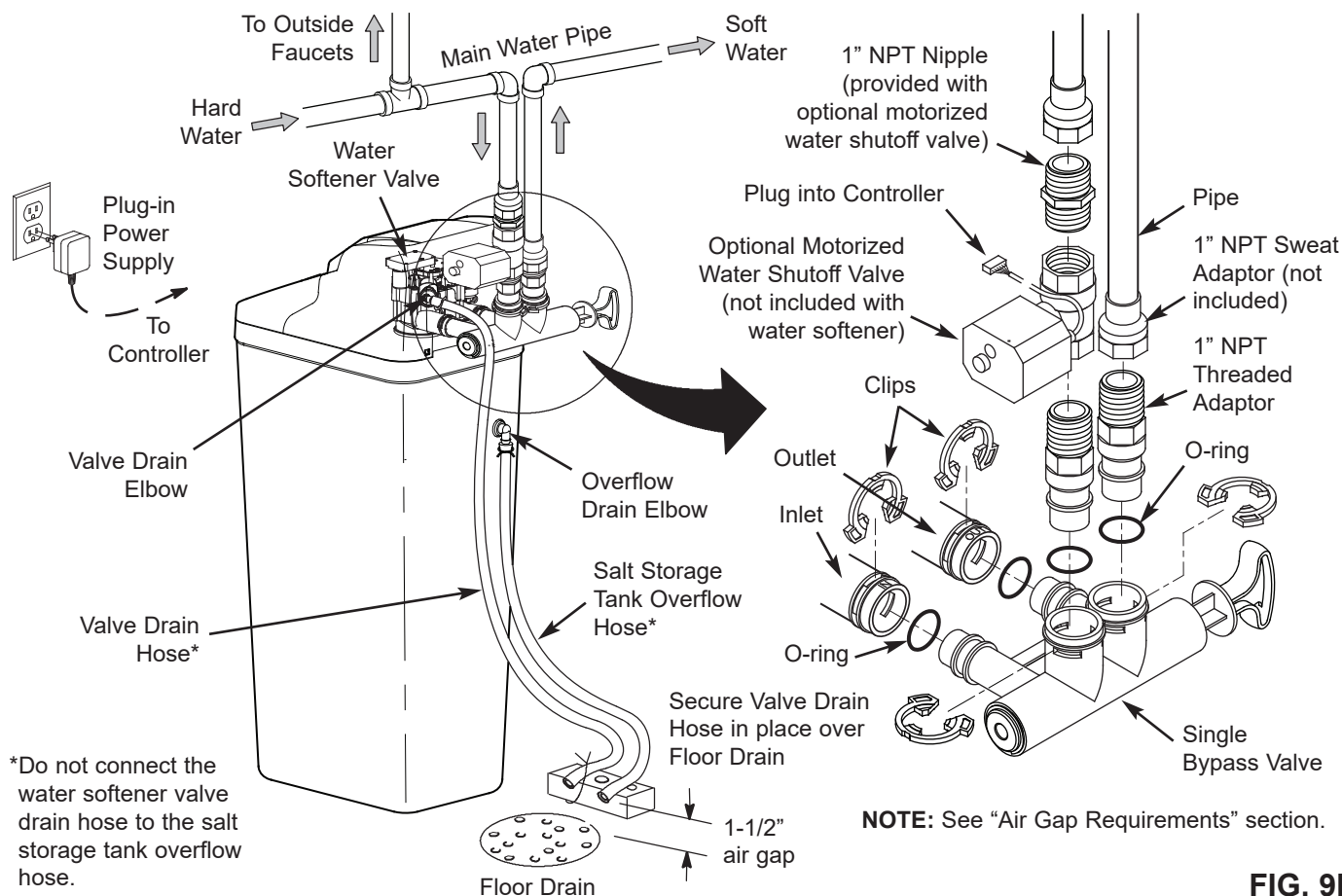

FIG. 9B

OPTIONAL: INSTALL THE MOTORIZED WATER SHUTOFF VALVE

If you purchased the optional water shutoff valve, install it in the plumbing upstream of the softener inlet. Figure 9B shows installation with the shutoff valve immediately upstream of the bypass valve inlet, using one of the softener's installation adaptors and a 1" NPT pipe nipple (not included).

The shutoff valve may also be installed in the plumbing farther upstream of the softener, making sure that the 10 foot long cable will reach the softener's electronic control board (See Figure 9C). The shutoff valve's inlet and outlet are female 1" NPT. Support the weight of the shutoff valve.

After completing plumbing, make sure that the water softener is not powered up, and plug the cable from the shutoff valve into the corresponding connector on the electronic control board (See Fig. 9C or Schematic on Page 27).

CAUTION: Do not place fingers into the motorized shutoff valve when it is plugged into the electronic controller.

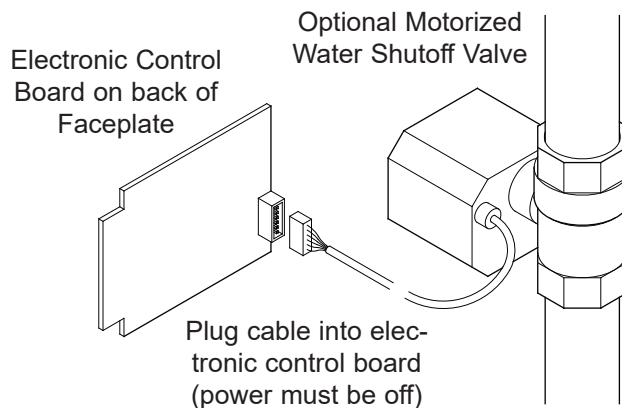

FIG. 9C

NOTE: The shutoff valve may be operated manually by pulling out and turning the knob on the shutoff valve body (See Fig. 65 on Page 27), although there is no need to do this when installing.

Installation Instructions

COMPLETE INLET AND OUTLET PLUMBING

Measure, cut, and loosely assemble pipe and fittings from the main water pipe to the inlet and outlet ports of the water softener valve. Be sure to keep fittings fully together, and pipes squared and straight.

Be sure hard water supply pipe goes to the water softener valve inlet side.

NOTE: Inlet and outlet are marked on the water softener valve. Trace the water flow direction to be sure hard water is to inlet.

IMPORTANT: Be sure to fit, align and support all plumbing to prevent putting stress on the water softener valve inlet and outlet. Undue stress from misaligned or unsupported plumbing may cause damage to the system.

Complete the inlet and outlet plumbing for the type of pipes you will be using.

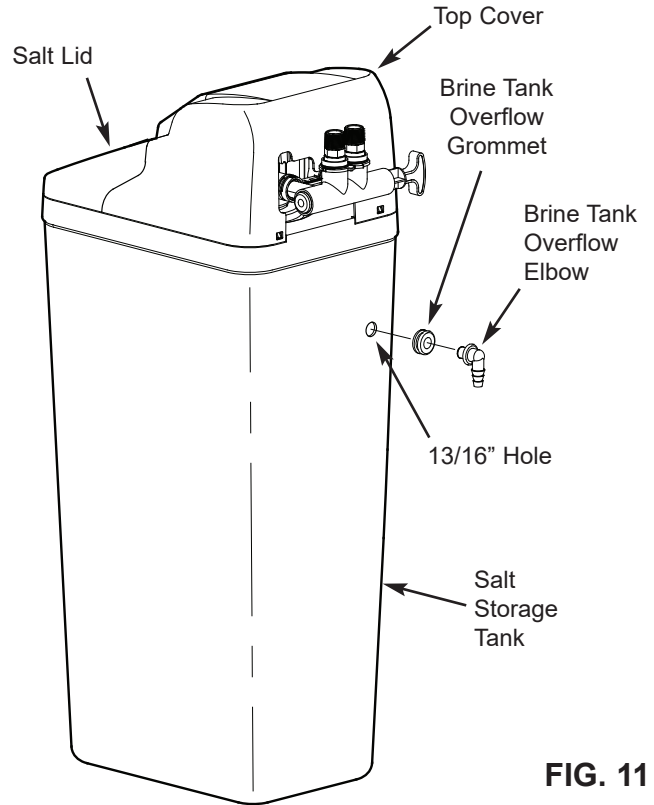

FIG. 11

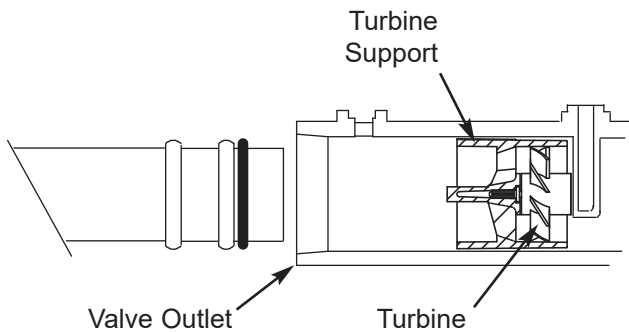

FIG. 10

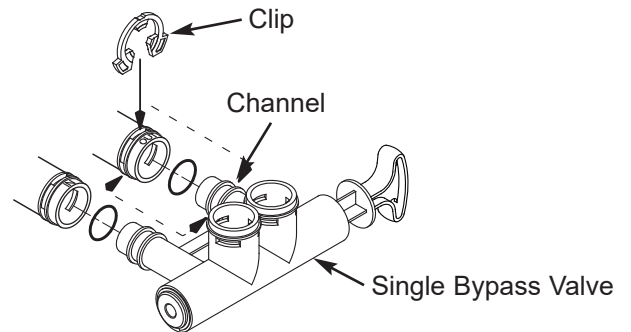

FIG. 12

Correct Assembly

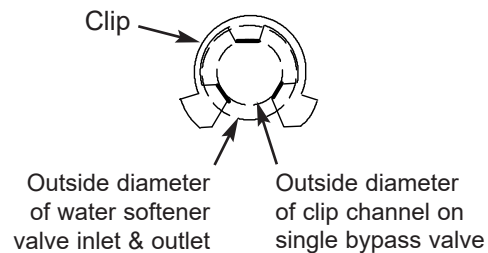

FIG. 13

NOTE: Be sure all 3 tabs of the clip go through the matching holes on the water softener valve inlet or outlet, and fully into the channel on the single bypass valve. Make sure that the tabs are fully seated.

Installation Instructions

COLD WATER PIPE GROUNDING

CAUTION: The house cold water pipe (metal only) is often used as a ground for the house electrical system. The 3-valve bypass type of installation, shown in Figure 8, will maintain ground continuity. If you use a plastic bypass valve at the unit, continuity is broken. To restore the ground, do the following:

1. Install a #4 copper wire across the removed section of main water pipe, securely clamping it at both ends (See Figure 14) - parts not included.

NOTE: Check local plumbing and electrical codes for proper installation of the ground wire. The installation must conform to them. In Massachusetts, plumbing codes of Massachusetts shall be conformed to. Consult with your licensed plumber.

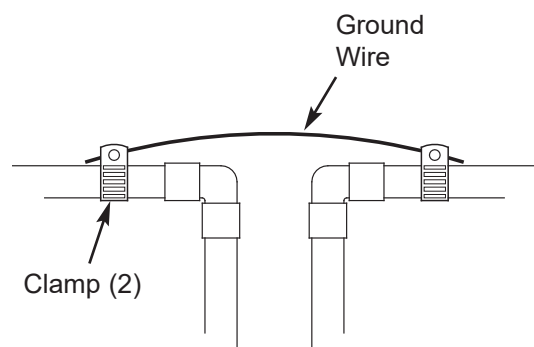

FIG. 14

INSTALL VALVE DRAIN HOSE

NOTE: See valve drain options on pages 6 & 7.

1. Measure, cut to needed length and connect the 3/8" drain line (provided) to the water softener valve drain fitting. Use a hose clamp to hold the hose in place.

IMPORTANT: If codes require a rigid drain line see "Valve Drain requirements" section.

2. Run the drain hose (or a rigid line) to the floor drain. Secure drain hose. This will prevent "whipping" during regenerations. **Be sure to provide a 1-1/2" minimum air gap to prevent possible sewer water backup.** See "Air Gap Requirements" section.

NOTE: In addition to a floor drain, you can use a laundry tub or standpipe as a drain point for this hose.. Avoid long drain hose runs, or elevating the hose more than 8 feet above the floor.

INSTALL SALT STORAGE TANK OVERFLOW HOSE

1. Measure, cut to needed length and connect the 3/8" drain line (provided) to the salt storage tank overflow elbow and secure in place with a hose clamp.
2. Route the hose to the floor drain, or other suitable drain point no higher than the drain fitting on the salt storage tank (This is a gravity drain). If the tank overfills with water, the excess water flows to the drain point. Cut the drain line to the desired length and route it neatly out of the way.

IMPORTANT: For proper operation of the water softener, do not connect the water softener valve drain tubing to the salt storage tank overflow hose.

ADD WATER AND SALT TO THE SALT STORAGE TANK

1. Using a container, add about three gallons of clean water into the salt storage tank.
2. Add salt to the storage tank. Use nugget, pellet or coarse solar salts with less than 1% impurities.

PLUG IN THE POWER SUPPLY

During installation, the water softener wiring may be moved or jostled from place. Be sure all leadwire connectors are secure on the back of the electronic board and be sure all wiring is away from the valve gear and motor area, which rotates during regenerations.

1. Plug the water softener's power supply into an electrical outlet that is not controlled by a switch and is approved by local codes.

NOTE: The water heater is filled with hard water and, as hot water is used, it will refill with conditioned water. In a few days, the hot water will be fully conditioned. To have fully conditioned hot water immediately, wait until the initial recharge is over. Then, drain the water heater (following instructions for water heater) until water runs cold.

PROGRAM THE CONTROLLER

1. Install the softener's top cover and salt lid.
2. Complete the Programming Steps on Pages 14 & 15.

Installation Instructions

RINSE OUT CARBON FINES

Small particles of carbon filtration material are generated during manufacturing and shipping, which will exit the media tank with the first water flow. These carbon “fines” are not harmful, but give the water a gray color and should be rinsed down the drain before any water from the conditioner is directed to the home’s faucets or water heater.

IMPORTANT: To avoid water or air pressure damage to conditioner inner parts, and to flush pipe chips or other residue from the water pipes, be sure to do the following steps exactly as instructed.

1. Make sure the water conditioner’s valve drain hose is hooked up and the open end directed to a floor drain, laundry tub or other suitable type of drain.
2. The system should be connected to electrical power.
3. Place bypass valve(s) in “bypass” position (see Figures 7 & 8). On a single valve, slide the stem inward to bypass. On a 3-valve bypass, close the inlet and outlet valves and open the bypass valve.
4. Fully open the house main water pipe shutoff valve.
5. Initiate a regeneration by pressing and holding for 3 seconds the RECHARGE button (see Figure 16 on page 14). The valve motor will start running and the valve will advance to the “Fill” position.
6. After you hear the valve motor stop running (valve in “Fill” position), press, but do not hold, the RECHARGE button. The valve will advance to the “Brine” position.
7. After you hear the valve motor stop running (valve in “Brine” position), press, but do not hold, the RECHARGE button. The valve will advance to the “Backwash” position.
8. Once the unit is in backwash, place bypass valve(s) in SERVICE, EXACTLY as follows:
 - a. Single Bypass Valve: Slowly, slide the valve stem outward toward service, pausing several times to allow the system to pressurize gradually.
 - b. 3-Valve Bypass: Fully close the bypass valve and open the outlet valve. Slowly open the inlet valve, pausing several times to allow the system to pressurize gradually.
9. Let the water conditioner complete the backwash and fast rinse cycles (takes about 20 minutes). When the regeneration ends, the conditioner’s valve returns to the service position.

SANITIZE THE WATER SOFTENER / SANITIZE AFTER SERVICE

Care is taken at the factory to keep your unit clean and sanitary. Materials used to make the unit will not infect or contaminate your water supply, and will not cause bacteria to form or grow. However, during shipping, storage, installation and operation, bacteria could get into the unit. For this reason, sanitizing as follows is suggested* when installing.

1. Open the salt lid and pour about 3 oz. (6 table-spoons) of household bleach into the softener brinewell.
2. Make sure the bypass valve(s) is in the “service” (open) position.
- 3 **Start a recharge:** Press the RECHARGE button and hold for 3 seconds, until “Recharge Now” begins to flash in the display. This recharge draws the sanitizing bleach into and through the water softener. Any air remaining in the unit is purged to the drain.
4. After the recharge has completed, fully open a cold water faucet, downstream from the softener, and allow 50 gallons of water to pass through the system. This should take at least 20 minutes. Close the faucet.

*Recommended by the Water Quality Association. On some water supplies, the unit may need periodic disinfecting.

Installation Instructions

TEST FOR LEAKS

To check for leaks, complete the following steps:

1. Fully open two nearby cold water faucets downstream from the water softener.
2. Observe steady flow from both faucets.
3. After about three minutes, open a hot water faucet for about one minute, or until all air is expelled, and then close this faucet.
4. Close both cold water faucets.
5. Check your plumbing work for leaks, and fix right away if any are found. Be sure to observe previous caution notes.

NOTE: If this procedure is performed on a new softener, water coming from the taps may initially be discolored. This normally occurs the first time water runs through the resin bed. The discoloration will not last more than a few minutes.

RESTART THE WATER HEATER

1. Turn on the electricity or fuel supply to the water heater and relight the pilot, if applicable.

NOTE: The water heater is filled with hard water and, as hot water is used, it refills with conditioned water. In a few days, the hot water will be fully conditioned. To have fully conditioned hot water immediately, wait until the initial recharge (previous step) is over. Then, drain the water heater (following instructions for water heater) until water runs cold.

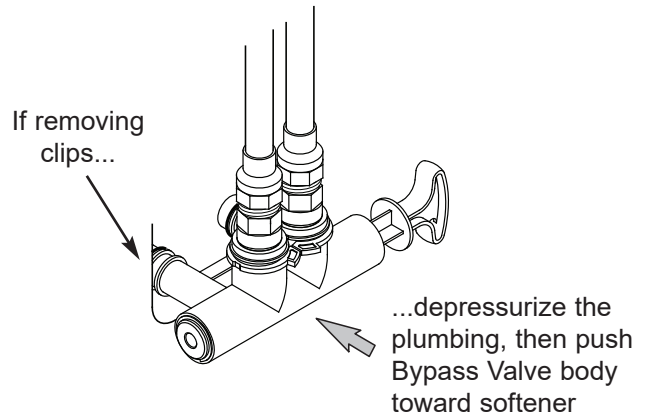

FIG. 15

Programming the Water Softener

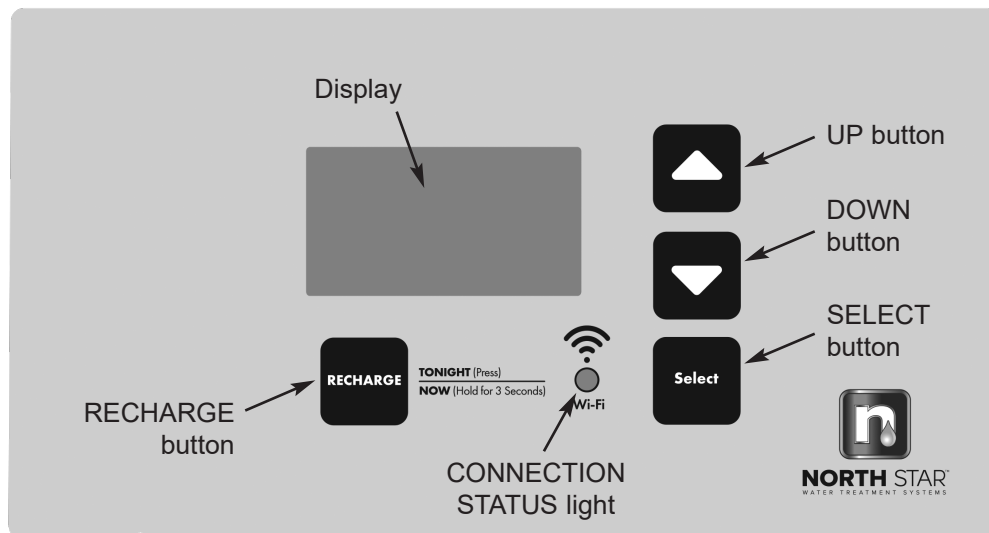

FIG. 16

PROGRAM THE SOFTENER

When the power supply is plugged into the electrical outlet, the model code (nHCP) and a software version number (example: r4.4), are briefly shown in the face-plate display. Then the words "SET TIME" appear and "12:00 PM" begins to flash.



FIG. 17

STEP 1. SET PRESENT TIME OF DAY

If the words "SET TIME" do not show in the display, press the SELECT button a few times until they do.



FIG. 18

1. Press the \triangle UP or ∇ DOWN buttons to set the present time. Up moves the display ahead; down sets the time back.

NOTE: Press buttons and quickly release to slowly advance the display. Hold the buttons down for fast advance.

NOTE: On Wi-Fi connected systems, the current time will be updated and maintained automatically via Wi-Fi.

2. When the correct time is displayed, press the SELECT button, and the display will change to show the "Hardness" screen.

STEP 2. SET WATER HARDNESS NUMBER

If you completed the previous step, the words "SET HARDNESS" should show in the display. Otherwise, press the SELECT button several times until they do.

1. Press the \triangle UP or ∇ DOWN buttons to set the hardness of your water supply, in grains per gallon. The default is 25.



FIG. 19

NOTE: If your water supply contains iron, compensate for it by adding to the water hardness number. For example, assume your water is 20 gpg hard and contains 2 ppm iron. Add 5 to the hardness number for each 1 ppm of iron. In this example, you would use 30 for your hardness number.

$$\begin{array}{r}
 20 \text{ gpg hardness} \\
 2 \text{ ppm iron} \times 5 = 10 \quad +10 \\
 \text{(times)} \qquad \qquad \qquad 30 \text{ HARDNESS NUMBER}
 \end{array}$$

2. When finished setting your water's hardness number, press the SELECT button, and the display will change to show the "Set Recharge Time" screen.

Programming the Water Softener

STEP 3. SET RECHARGE (REGENERATION) START TIME

If you completed the previous step, the words "SET RECHARGE TIME" should show in the display. Otherwise, press the SELECT button several times until they do.



FIG. 20

1. The softener's default recharge start time is 02:00. This is normally a time of day when water is not being used in the household. Hard water bypasses the softener if the household draws water during the recharge cycle. If a different recharge start time is desired, press the Δ UP or ∇ DOWN buttons to change the time, in 1-hour increments.
2. When the desired recharge start time is displayed, press the SELECT button, and the display will change to show the "Set Salt Type" screen.

STEP 4. SET SALT TYPE

If you completed the previous step, either "NaCl" (for Sodium Chloride) or "KCl" (for Potassium Chloride) should show in the display. Otherwise, press the SELECT button several times until one of them does.



FIG. 21

1. Press the Δ UP or ∇ DOWN buttons to set the type of salt you will be using in your water softener. The default is NaCl (standard Sodium Chloride water softener salt). If you will be using KCl (Potassium Chloride) instead, be sure to set salt type to KCl. This setting adjusts the regeneration cycle times to compensate for the different rate at which KCl dissolves. See also Page 22 for more information on salt types.
2. When the correct salt type is displayed, press the SELECT button, and the display will change to show the "Set Salt Level" screen.

STEP 5. SET SALT LEVEL

If you completed the previous step, the words "SET SALT LEVEL" should show in the display. Otherwise, press the SELECT button until they do.

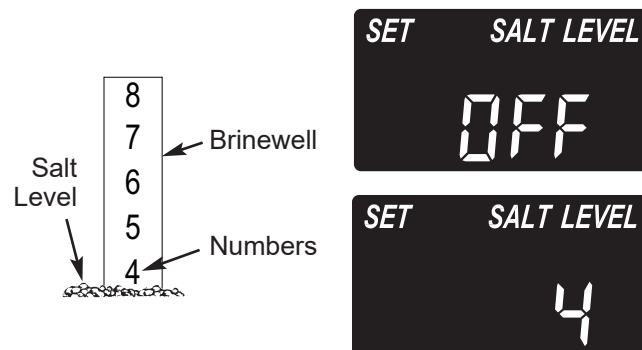

FIG. 22

1. Lift the salt lid and level the salt in the storage tank.
2. The salt level scale, on the brinewell inside the tank, has numbers from 0 to 8 (see Fig. 22). Observe the highest number the leveled salt is at, or closest to.
3. Press the Δ UP or ∇ DOWN buttons until the number on the screen corresponds to the salt level. At level 2 or below, "LOW SALT LEVEL" will flash in the display. If you wish to turn this feature off, press the ∇ DOWN button past 0, and the word "OFF" flashes in the display.
4. When finished setting the salt level, press the SELECT button. The display returns to the normal time of day screen (Fig. 23).



FIG. 23

SALT LEVEL MONITOR SYSTEM

You must set salt level each time salt is added to the water softener. The salt monitor system estimates salt levels, and accuracy will vary with different salts. At level 2 or below, "LOW SALT LEVEL" will flash in the display (Fig. 24) to remind you to add salt.



FIG. 24

Programming the Water Softener

EXTRA RECHARGE

Sometimes, a manually initiated recharge (regeneration) may be desired, or needed. Two examples are:

- You have used more water than usual (guests visiting) and you may run out of soft water before the next automatic regeneration.
- You did not add salt to the softener before it ran out. Add salt to the softener before regenerating.

You can start a regeneration immediately, or you can set the controller to regenerate at the next preset recharge time (2:00 AM, or as set).

RECHARGE NOW

Press the RECHARGE button and hold for 3 seconds, until the words “RECHARGE NOW begin to flash in the display



FIG. 25

The softener enters the fill cycle of regeneration immediately. This regeneration will take about 2 hours to complete. Then, you will have soft water again.

NOTE: If the “Clean Feature” is set ON, the normal regeneration cycle is preceded by a cleaning backwash and rinse.

RECHARGE TONIGHT

If you do not want to start an immediate recharge, but would like an extra recharge at the next preset recharge start time, do the following to schedule a recharge:

Press and release (do not hold) the RECHARGE button. “RECHARGE TONIGHT” will begin flashing in the display, and the softener will begin regeneration at the next preset recharge time (2:00 AM, or as set).

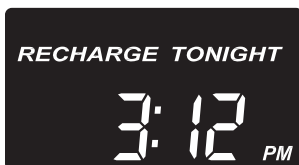

FIG. 26

If you decide to cancel the regeneration before it starts, press and release the RECHARGE button once more. “RECHARGE TONIGHT” will stop flashing in the display.

PROGRAM MEMORY

If electrical power to the softener goes off, the time display is blank but the electronic controller keeps the correct time for several hours. When electrical power comes on again, you will have to reset the present time only if the display is flashing. The HARDNESS and RECHARGE TIME never require resetting unless a change is desired. Even if the clock is incorrect after a long power outage, the softener works as it should to keep your water soft, however, regenerations may occur at the wrong time of day until you reset the clock to the correct time of day.

Connecting the System to Wi-Fi

STEP 1. DOWNLOAD THE iQua™ APP

Go to the App Store or Google Play and download the **iQua™** app. This must be installed on your phone to set up an account and connect your water softener to the “cloud”.

STEP 2. SET UP YOUR ACCOUNT

1. Activate the **iQua™** app.
2. On the welcome screen, click **Create an Account**.

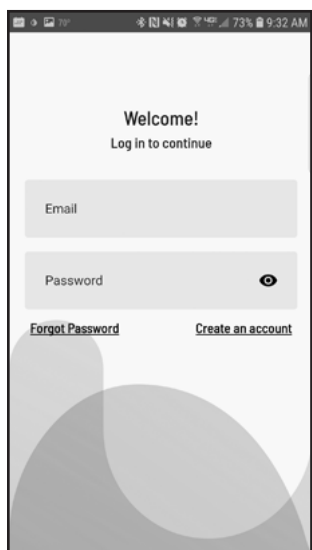

FIG. 27

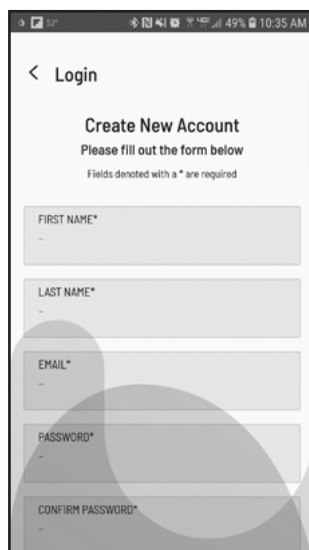

FIG. 28

3. Fill in the required fields with your information (name, phone number, address, etc.). Enter the e-mail address you want to receive notifications. Create a password to access your account.
4. Agree to the terms and press **Complete**.

5. A message to check your e-mail appears. An activation e-mail has been sent to the address you provided when creating the account. If you don't see it your inbox, check your spam or junk folders, and flag it as safe so that future notifications from myiqua.com will not be blocked. Wait to click the link in this e-mail until you have put the water softener control into Connect Mode, as follows.

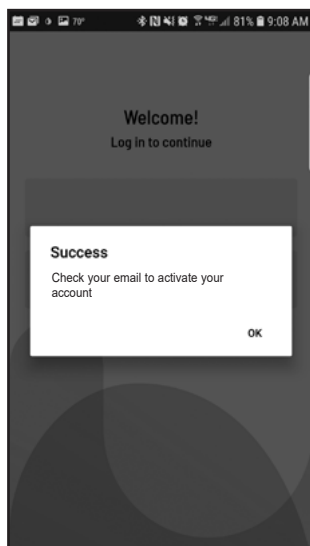

FIG. 29

STEP 3. PUT WATER SOFTENER CONTROL INTO CONNECT MODE

1. If you haven't already done so, program the water softener with time, hardness, salt level, etc., as shown on pages 14 & 15.
2. Make sure that the softener's display shows the current time, without the word “SET”. Press the **SELECT** button several times if “SET” shows.
3. On the water softener's front panel (see Fig. 30), press both the **△ UP** and **▽ DOWN** buttons, and hold them for 3 seconds.

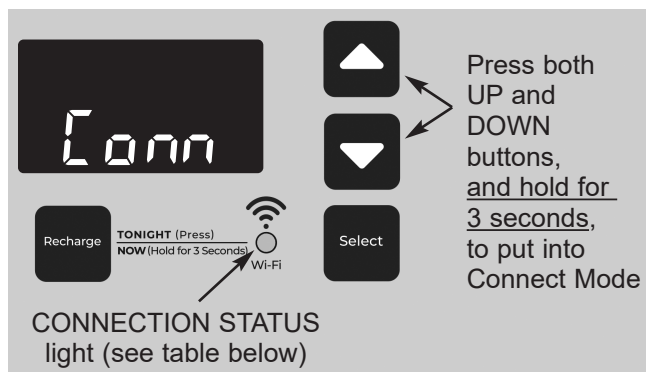

FIG. 30

4. Release the buttons when “Conn” appears in the display (See Fig. 30) and the connection status light begins flashing amber.
5. The system is now in Connect Mode, ready to be connected to the “cloud”, and will remain for 15 minutes. If Connect Mode has “timed out” and the light is off, you can enter Connect Mode again by pressing both the **△ UP** and **▽ DOWN** buttons and holding them for 3 seconds.

Connection Status light indication	Status
Flashing Amber (for up to 15 minutes)	System is in Connect Mode, waiting to be connected to the “cloud” via the home’s wireless router.
Green	System successfully connected to the “cloud” and registered.
Red	System is currently receiving an over-the-air update.
No light	System not currently connected to the “cloud”.

6. With the system in the Connect Mode, follow the instructions on the next page to use the app to connect your water softener to the “cloud” via the home’s wireless router.

Connecting the System to Wi-Fi

STEP 4. CONNECT AND REGISTER YOUR WATER SOFTENER

1. If you completed the steps on the previous page, you will have received an account activation e-mail from myiqua.com. Open this e-mail and click on the **Activate Account** link.
2. Sign in to your account using the e-mail address and password you provided when setting it up.
3. The app screen will change to show **Searching for your device...**
4. Verify that the softener is still in Connect Mode (flashing amber light). When the display on the water softener changes from “Conn” to “C-1”, it is communicating with your phone.

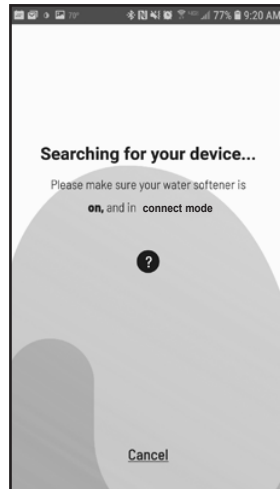

FIG. 31



FIG. 32



FIG. 33

5. The app screen will change to show a list of devices in range. There should be a name that begins with **WCD**, followed by a serial number. This is your North Star water softener. Select it and the screen changes to **Pairing Your Device**.

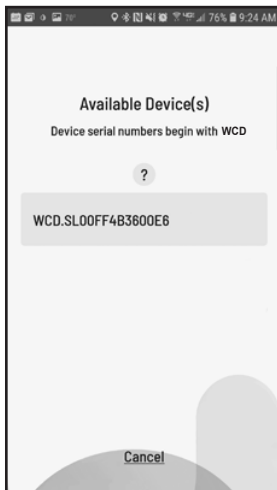

FIG. 34

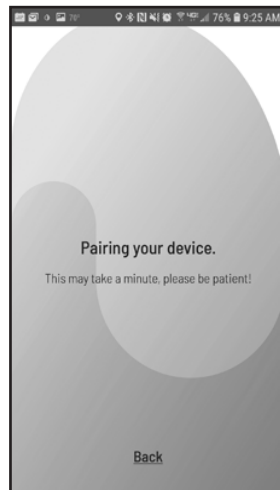

FIG. 35

6. The app screen will change to show a list of wireless networks in range. Select your home's wi-fi router and enter your wi-fi network password.

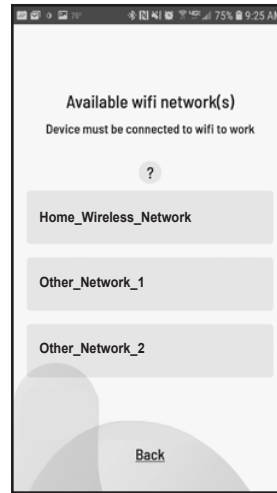

FIG. 36

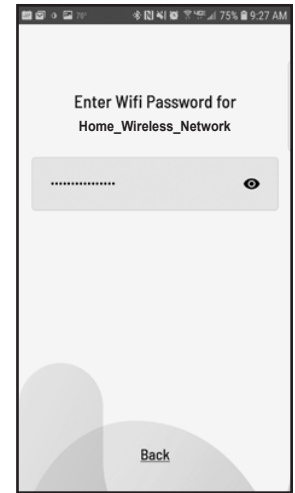

FIG. 37

7. The water softener's display will change to “C-2” when the system connects with the home's wireless network. It will change again to “C-3” when it connects with the iQua™ server in the “cloud”.



FIG. 38



FIG. 39

8. The app will prompt you to provide a nickname for your softener. This will be displayed on the “Devices” list when you sign in to the app. After entering the nickname, press **Complete Setup**.

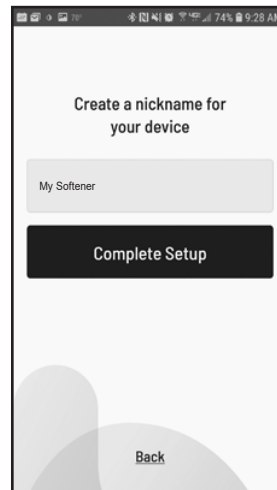

FIG. 40

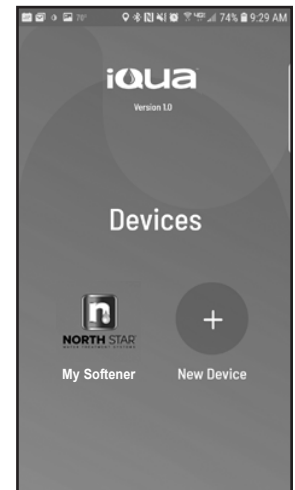

FIG. 41

Controller Features

OPTIONAL SETTINGS:

- SALT EFFICIENCY
- CLEAN FEATURE
- CLEAN FEATURE MINUTES
- MAXIMUM DAYS BETWEEN REGENERATIONS
- 97% FEATURE
- 12 / 24 HOUR CLOCK
- BACKWASH & FAST RINSE TIMES
- AUXILIARY OUTPUT CONTROL

1. To set any of these options, press and hold the SELECT button for 3 seconds until "000 - -" shows in the display.



FIG. 42

Then press (do not hold) SELECT again to display one of the "Salt Efficiency" screens shown below.

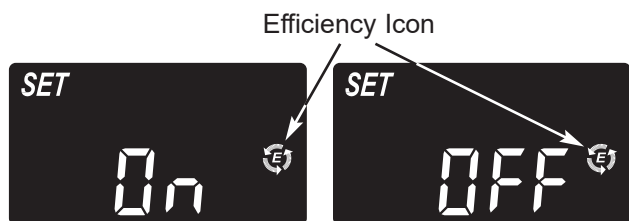

FIG. 43

SALT EFFICIENCY: When this feature is ON, the water softener will operate at salt efficiencies of 4000 grains of hardness per pound of salt or higher. The softener may recharge more often using smaller salt dosage and less water. This softener is shipped with the efficiency feature set OFF. Use the Δ UP or ∇ DOWN buttons to change between OFF and ON. An efficiency icon will be displayed when this feature is ON.

Displayed when efficiency is set to "ON"



FIG. 44

California Efficiency Requirement

Your North Star Water Softener has a "High Efficiency" feature that can be set ON or OFF. This softener is shipped with the efficiency feature set OFF, which will utilize the maximum rated capacity while most often achieving maximum salt efficiencies. When installing this unit in the State of California, you MUST turn the efficiency feature ON. The softener may initiate more frequent recharges, but it will operate at 4000 grains per pound of salt or higher.

2. Press SELECT again to display the "Set Clean" screen.



FIG. 45

CLEAN: This feature is beneficial on water supplies containing iron and/or high amounts of sediments (sand, silt, dirt, etc.). When set to ON, a backwash and fast rinse cycle will occur first, preceding the normal regeneration sequence. This provides extra cleaning of the resin bed before it is regenerated with the salt brine. To conserve water, if your water supply does not contain iron or sediments, be sure this feature is set to OFF. The default is OFF. Use the Δ UP or ∇ DOWN buttons to change between OFF and ON.

3. Press SELECT again to display the "Set Clean Time" screen.

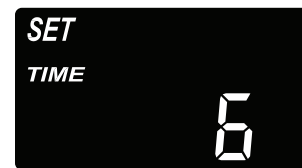

FIG. 46

CLEAN FEATURE MINUTES: If you have set the Clean Feature ON, the length of the extra backwash cycle automatically is set to 6 minutes. However, you can adjust this time from 1 to 15 minutes in length. To change this cycle time, use the Δ UP button to increase the time, or the ∇ DOWN button to shorten the time. If no change is desired, continue to next step.

Controller Features

- Press SELECT again to display the “Recharge Days” screen.



FIG. 47

MAXIMUM DAYS BETWEEN REGENERATIONS: The electronic controller automatically determines regeneration frequency. This provides the greatest operating efficiency and, under most conditions this feature will be left in its default mode. However, you can set this feature to force a regeneration every set number of days. You may want to do this if, for example, your water supply contains iron and you want the softener to regenerate at least once every few days to keep the resin bed clean. Use the Δ UP or ∇ DOWN buttons to change the number of days (up to 15). If no change is desired, continue to next step.

- Press SELECT again to display the “97%” screen.



FIG. 48

97% FEATURE: The 97% Feature can save salt and water by regenerating when 97% of the softener’s capacity has been used up. With this feature ON, the regeneration can occur at any time (whenever the system has reached 97% of its capacity). The default is OFF. If this feature is desired, turn it on by pressing the Δ UP button.

- Press SELECT again to display the “12 or 24 hr” screen.



FIG. 49

12 OR 24 HOUR CLOCK: All time displays are shown in 12 hour (AM/PM) time format at the default setting. If 24 hour time format is desired, set to 24 hr by pressing the Δ UP button.

- Press SELECT again to display the “bA-” backwash time setting screen.



FIG. 50

BACKWASH & FAST RINSE TIMES: If you experience salty tasting water after regeneration, you may need to increase the backwash and fast rinse times. The default backwash time is 13 minutes and the default fast rinse time is 6 minutes. However, you may increase or decrease the backwash and fast rinse times, in 1 minute increments. If you wish to change the backwash time, use the Δ UP or ∇ DOWN buttons to set the backwash time between 1 and 30 minutes.* Then press SELECT to display the “Fr-” fast rinse time setting screen.



FIG. 51

If you wish to change the fast rinse time, use the Δ UP or ∇ DOWN buttons to set the fast rinse time between 1 and 30 minutes.*

* Setting backwash and/or fast rinse times too low may result in salty tasting water after regeneration.

Controller Features

8. Press SELECT again to display the “SET CTRL” screen.



FIG. 52

AUXILIARY OUTPUT CONTROL: The electronic controller’s auxiliary output may be used to operate various types of external equipment, such as a chlorine generator or chemical feeder. It provides a 24V DC, up to 500 mA, current from terminal J8 on the electronic control board (see Schematic on Page 27). The table, below, explains the choices available for when the auxiliary output will be on during various portions of the softening cycle:

SELEC-TION	NAME	AUXILIARY OUTPUT FUNCTION
OFF	Off	Remains off indefinitely.
BP	Bypass	On during the entire regeneration.
CL	Chlorine	On during the brine draw portion of the regeneration.
FS	Flow Switch	On when water is flowing past the turbine. It will shut off 8 seconds after water flow stops.
CF	Chemical Feeder	After the set volume of water has flowed past the turbine, turns on for the time set (see Step 9 to set volume and time).
FR	Fast Rinse	On during the fast rinse portion of the regeneration.
ON	On	Remains on indefinitely.

The default is OFF. If you wish to change to one of the other selections in the table, use the Δ UP or ∇ DOWN buttons to display the desired selection.

9. Press SELECT when the desired selection is displayed. If you selected anything other than CF, the display will return to the normal run (time of day) screen. If you selected CF (Chemical Feeder), there will be two additional settings to make for operating the chemical feeder.



FIG. 53

CHEMICAL FEEDER TRIP VOLUME: If you have set the auxiliary output control to CF (Chemical Feeder), you will need to set the volume of water which must flow past the turbine before the auxiliary output is turned on. With the above screens alternating, use the Δ UP or ∇ DOWN buttons to set the trip volume, in gallons. Then press SELECT to display the screen shown below.



FIG. 54

CHEMICAL FEEDER TIME: Use the Δ UP or ∇ DOWN buttons to set the length of time, in seconds, that the auxiliary output will be turned on.

10. Press SELECT to return to the normal run (time of day) screen.



FIG. 55

Routine Maintenance

ADDING SALT

Open the salt lid and check the salt storage level frequently. If the water softener uses all the salt before you refill it, you will experience hard water. Until you have established a refilling routine, check the salt every two or three weeks. Always add if less than 1/4 full.

NOTE: In humid areas, it is best to keep the salt storage level lower, and to refill more often to avoid salt “bridging”.

Recommended Salt: Nugget, pellet or coarse solar salts with less than 1% impurities.

Salt Not Recommended: Rock salt, high in impurities, block, granulated, table, ice melting, ice cream making salts, etc.

BREAKING A SALT BRIDGE

Sometimes, a hard crust or salt “bridge” forms in the brine tank. It is usually caused by high humidity or the wrong kind of salt. When the salt “bridges,” an empty space forms between the water and the salt. Then, salt will not dissolve in the water to make brine. Without brine, the resin bed is not recharged and hard water will result.

If the storage tank is full of salt, it is difficult to tell if you have a salt bridge. A bridge may be underneath loose salt. Take a broom handle, or like tool, and hold it next to the water softener. Measure the distance from the floor to the rim of the water softener. Then, carefully push the broom handle straight down into the salt. If a hard object is felt before the pencil mark is even with the top, it is most likely a salt bridge. Carefully push into the bridge in several places to break it. Do not use any sharp or pointed objects as you may puncture the brine tank. Do not try to break the salt bridge by pounding on the outside of the salt tank. You may damage the tank.

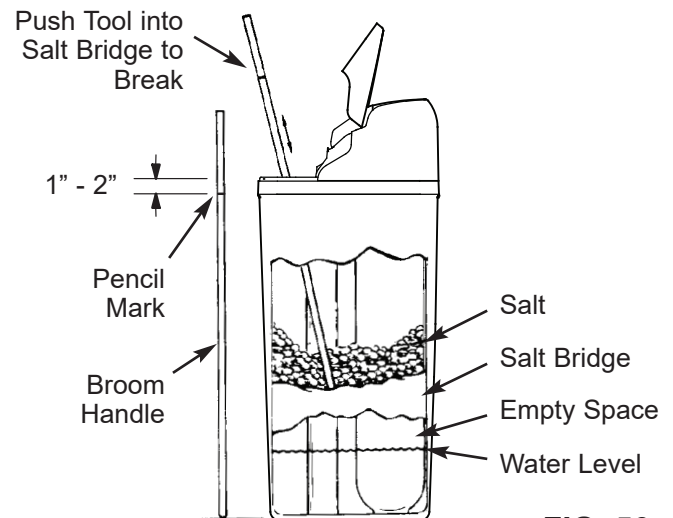
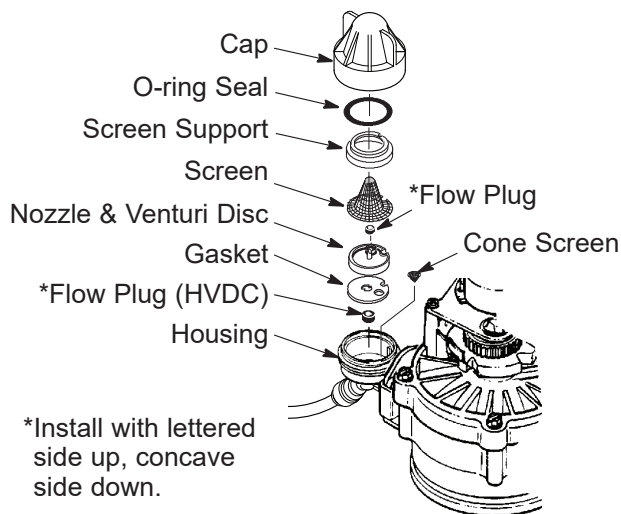

FIG. 56

Routine Maintenance

CLEANING THE NOZZLE & VENTURI

A clean nozzle & venturi (See Figure 57) is a necessity for the water softener to work properly. This small component creates the suction to move brine from the brine tank, into the resin tank. If it should become plugged with sand, silt, dirt, etc., the water softener will not work, and hard water will result.



IMPORTANT: Be sure small hole in the gasket is centered directly over the small hole in the nozzle & venturi housing. Be sure the numbers are facing up.

FIG. 57

To get access to the nozzle & venturi, remove the water softener's top cover. Put the bypass valve(s) into the bypass position. Be sure the water softener is in soft water (service) cycle (no water pressure at nozzle & venturi). Then, holding the nozzle & venturi housing with one hand, unscrew the cap. Do not lose the o-ring seal. Lift out the screen support and screen. Then, remove the nozzle & venturi disc, gasket and flow plug(s). Wash the parts in warm, soapy water and rinse in fresh water. Be sure to clean both the top and bottom of the nozzle & venturi disc. If needed, use a small brush to remove iron or dirt. Do not scratch, misshape, etc., surfaces of the nozzle & venturi.

Carefully replace all parts in the correct order. Lubricate the o-ring seal with silicone grease and locate in place. Install and tighten the cap by hand, while supporting the housing. Overtightening may break the cap or housing. Put the bypass valve(s) into service (soft water) position.

Recharge the softener to reduce water level in the tank. This will also assure that the softener is completely recharged and ready to provide softened water again. Check the water level in the tank by looking down the brinewell. If the water level does not drop after a recharge, the problem has not been resolved. Contact us at: info@northstarwater.com

PROTECT THE WATER SOFTENER FROM FREEZING

If the softener is installed where it could freeze (summer cabin, lake home, etc.), you must drain all water from it to stop possible freeze damage. To drain the softener:

1. Close the shut-off valve on the house main water pipe, near the water meter or pressure tank.
2. Open a faucet in the soft water pipes to vent pressure in the softener.
3. Move the stem in the single bypass valve to bypass. Close the inlet and outlet valve in a 3 valve bypass system, and open the bypass valve. If you want water in the house pipes again, reopen the shut-off valve on the main water pipe.
4. Unplug the power supply at the wall outlet. Open the salt lid and remove the softener's top cover. Take off both drain hoses if they will interfere with moving the softener into position over the drain.
5. Carefully remove the large holding clips at the softener inlet and outlet. Separate the softener from the plastic installation adaptors, or from the bypass valve.
6. Lay a piece of 2 inch thick board near the floor drain (See Figure 58).
7. Move the softener close to the drain. Slowly and gently, tip it over until the rim rests on the wood block with the inlet and outlet over the drain. Do not allow the softener's weight to rest on the inlet and outlet fittings or they may break.
8. Tip the bottom of the softener up a few inches and hold until all water has drained. Leave the softener laying like this until you are ready to use it. Plug the inlet and outlet with clean rags to keep dirt, bugs, etc. out.

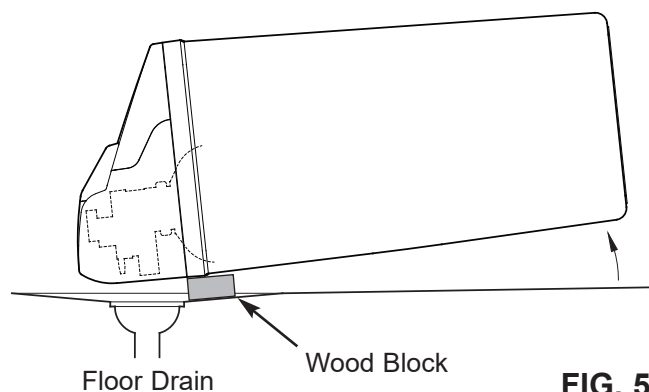

FIG. 58

Troubleshooting Guide

PROBLEM	CAUSE	CORRECTION
No soft water	1. No salt in the storage tank.	Refill with salt and then use RECHARGE NOW feature.
No soft water & display is blank	1. Power supply unplugged at wall outlet, or power cable disconnected from back of electronic board or power supply malfunction.	Check for loss of power and correct. Reset electronic controls and then use RECHARGE NOW feature.
	2. Fuse blown, circuit breaker popped, or circuit switched off (See "Program Memory" on Page 16).	Replace fuse, reset circuit breaker, or switch circuit on, and then use RECHARGE NOW feature.
	3. Electronic control board malfunction.	Replace electronic control board (See Page 29).
No soft water & salt level not dropping	1. Salt storage tank "bridged".	Refer to "Breaking a Salt Bridge" section to break.
	2. Bypass valve(s) in "bypass" position.	Move bypass valve(s) to "service" position.
No soft water & salt storage tank full of water, water running to drain while unit is in the soft water cycle	1. Dirty, plugged or damaged nozzle & venturi assembly	Take apart, clean and inspect nozzle & venturi (See "Cleaning the Nozzle & Venturi" section).
	2. Inner valve fault causing leak.	Replace seals and rotor.
	3. Valve drain hose is plugged.	Hose must not have any kinks, sharp bends or any water flow blockage (See "Valve Drain Requirements" section).
	4. Valve drain line and Salt Storage Tank overflow drain connected together by a tee.	Disconnect tee and run separate drain lines.
	5. Low or high system water pressure (low pressure may disrupt brine draw during recharge, high pressure may cause inner valve parts failure).	If pressure is low, increase well pump output to a minimum 20 psi. If daytime pressure is over 100 psi, add a pressure reducing valve in the supply pipe to the softener. Contact a licensed plumber.
	6. Brine float dirty or broken.	Clean or replace Brine Valve Float Assembly.
	7. Leak between valve and resin tank.	Replace o-rings between resin tank and valve.
Water hard sometimes	1. Incorrect time set.	Check and change time setting.
	2. Incorrect water hardness set.	Refer to "Set Water Hardness" section to set correctly.
	3. Incorrect model code programmed.	Refer to "Program the Water Softener" section to set correctly.
	4. Hot water being used when softener is regenerating.	Avoid using hot water while the softener is regenerating, as the water heater will fill with hard water.
	5. Possible increase in water hardness.	Test untreated water for hardness and iron, and program the water softener accordingly (See "Set Water Hardness") section to set.
	6. Leaking faucet or toilet valve. Excessive water usage.	A small leak can waste hundreds of gallons of water in a few days. Fix all leaks and always fully close faucets.
Iron in water	1. Clear water iron in water supply.	Test untreated water for hardness and iron, and program the water softener accordingly (See "Set Water Hardness") section to set.
	2. Iron in soft water.	Clean resin bed with Resin Bed Cleaner. Follow instructions on package.
	3. Bacterial or organic bound iron.	Cannot be treated by water softener.
Resin in household plumbing	1. Crack in distributor or riser tube.	Replace resin tank assembly.
Salt storage tank leaking	1. Crack in brine tank.	Replace salt storage tank assembly.
Motor stalled or clicking	1. Motor malfunction or internal valve fault causing high torque on motor.	a. Replace rotor/seal. b. Replace motor & switch.
Error code E1, E3 or E4 appears	1. Fault in wiring harness or connections to position switch.	Replace wiring harness or connections to position switch.
	2. Fault in switch.	Replace switch.
	3. Fault in valve causing high torque.	Replace rotor/seal.
	4. Motor inoperative.	Replace motor.
Error code E5	1. Electronic control malfunction.	Replace electronic control board.
Status light off, but display is not blank	1. System not connected by Wi-Fi to the "cloud".	a. If internet service goes down, connection will automatically resume when internet service comes back up. b. If the home's wireless router was replaced, reconnect and register the system, as shown on Pages 17 & 18.

Troubleshooting

AUTOMATIC ELECTRONIC DIAGNOSTICS

This water softener self-monitors electronic components and circuits for correct operation. If a malfunction occurs, an error code appears in the display.



FIG. 59

Error Codes 01, 02, 03, 04 & 05:

These are the water softener error codes unrelated to the optional water shutoff valve. While one is in the display, the SELECT button remains operational so the service person can perform the Manual Advance Diagnostics, below, to further isolate the problem.

Procedure for removing error codes 01 through 05 from display:

1. Unplug power supply from electrical outlet.
2. Correct problem.
3. Plug power supply back in.
4. Wait 8 minutes. The error code will return if the problem was not corrected.

Error Codes 07, 08 & 09:

These error codes indicate a problem with the optional water shutoff valve. Make sure that the water shutoff valve is still plugged into the water softener's control board. To clear one of these codes from the display, press the RECHARGE button and hold for 3 seconds. If the error code is displayed again after a minute or two, the water shutoff valve probably needs to be replaced.

MANUAL ADVANCE DIAGNOSTICS

Use the following procedures to advance the water softener through the regeneration cycles to check operation.

Remove the top cover to expose the valve and observe cam and switch operation during valve rotation.

1. Press and hold SELECT for 3 seconds until "000" shows in the display, then release.
2. The 3 digits indicate water meter operation:
 - 000 (steady) = Soft water not in use, and no flow through the meter.Open a nearby soft water faucet.
 - 000 to 140 (continual) = Repeats for each gallon of water passing through the meter.

3. The letter "P" and a dash (or dashes) indicate POSITION switch operation (See Figure 60). If the letter appears, the switch is closed. If the dash shows, the switch is open.

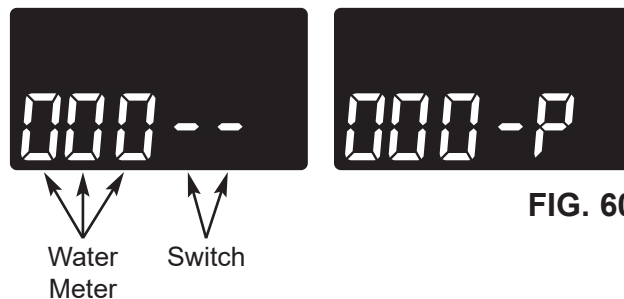

FIG. 60

4. Use the RECHARGE button to manually advance the valve into each cycle and check correct switch operation.

NOTE: Be sure water is in contact with the salt, and not separated by a salt bridge (See "Breaking A Salt Bridge" section).

5. While in this diagnostic screen, the following information is available and may be beneficial for various reasons. This information is retained by the computer from the first time electrical power is applied to the electronic controller.
 - a. Press the \triangle UP button to display the number of days this electronic control has had electrical power applied.
 - b. Press the ∇ DOWN button to display the number of regenerations initiated by this electronic control since the code number was entered.
6. Press and hold the SELECT button until the model code (nHCP) shows in the display. This code identifies the softener model. If an incorrect model code is displayed, the softener will operate on incorrect configuration data.



FIG. 61

7. To change the code number, press the \triangle UP or ∇ DOWN button until the correct code shows.
8. To return to the present time display, press the SELECT button.

Troubleshooting

RESETTING TO FACTORY DEFAULTS

To reset the electronic controller to its factory default for all settings (time, hardness, etc.):

1. Press the SELECT button and hold it until the display changes twice to show "SET" and the flashing model code.
2. Press the \triangle UP button (a few times, if necessary) to display a flashing "SoS".



FIG. 62

3. Press the SELECT button, and the electronic controller will restart.
4. Set the present time, hardness, etc., as described on pages 14 & 15.

MANUAL ADVANCE REGENERATION CHECK

This check verifies proper operation of the valve motor, brine tank fill, brine draw, regeneration flow rates, and other controller functions. Always make the initial checks first, and perform the manually initiated electronic diagnostics.

NOTE: The display must show a steady time (not flashing). If an error code shows, first press the SELECT button to enter the diagnostic display.

1. Press the RECHARGE button and hold for 3 seconds. RECHARGE begins to flash as the softener's valve advances from the service to fill position.
2. Shine a flashlight down the brinewell and observe fill water entering the tank.
3. If water does not enter the tank, look for an obstructed nozzle, venturi, fill flow plug, brine tubing, or brine valve riser pipe.
4. After observing fill, press the RECHARGE button to move the softener into brining. A slow flow of water to the drain will begin. Verify brine draw from

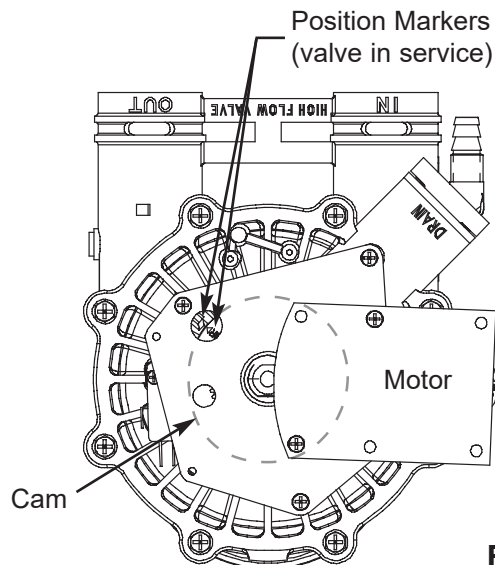

FIG. 63

the brine tank by shining a flashlight into the brinewell and observing a noticeable drop in the liquid level.

5. If the softener does not draw brine:
 - nozzle and/or venturi dirty
 - nozzle and venturi not seated properly on gasket
 - restricted drain (check drain fitting and hose)
 - ineffective nozzle and venturi seal
 - other inner valve problem (rotor seal, rotor & disc, wave washer, etc.)

NOTE: If water system pressure is low, an elevated drain hose may cause back pressure, stopping brine draw.

6. Again press RECHARGE to move the softener into backwash. Look for a fast flow of water from the drain hose.
7. An obstructed flow indicates a plugged top distributor, backwash flow plug or drain hose.
8. Press RECHARGE to move the softener into fast rinse. Again look for a fast drain flow. Allow the softener to rinse for a few minutes to flush out any brine that may remain in the resin tank from the brining cycle test.
9. To return the softener to service, press RECHARGE once more.

Wiring Schematic

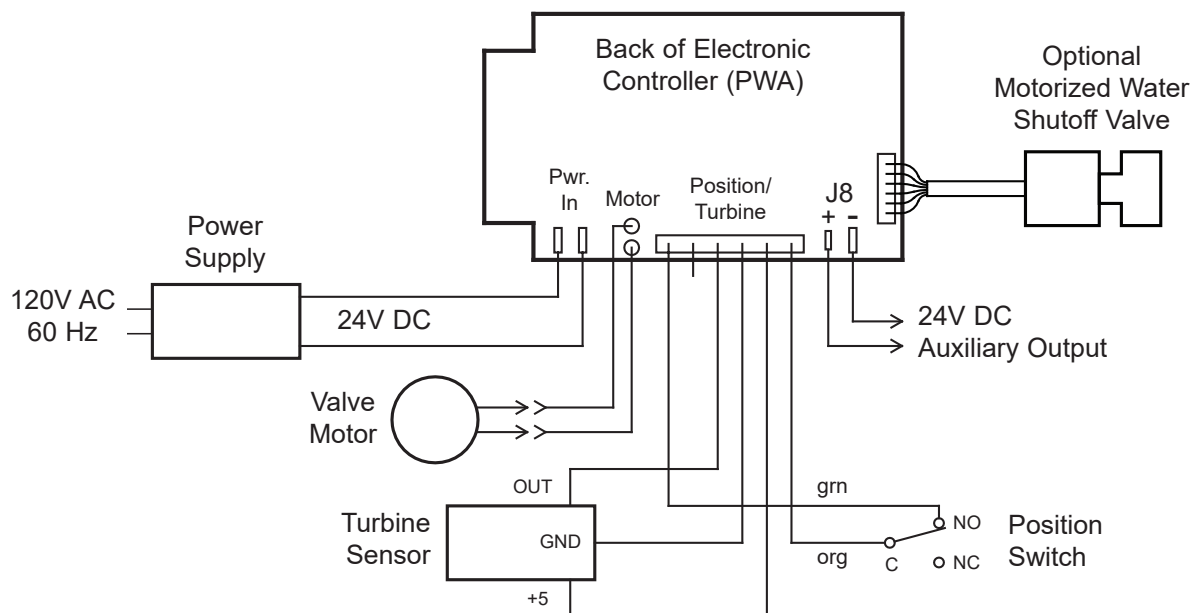

FIG. 64

Optional Motorized Water Shutoff Valve

The Motorized Water Shutoff Valve (sold separately) may be used with this North Star Wi-Fi connected water softener and the **iQua™** app to remotely turn off the home's water supply. For example, you may want to turn off the water when going away on vacation. Install the motorized shutoff valve in the plumbing, upstream of the softener (see page 9), and plug the cable into the softener's electronic control board with the power off (see page 9 and Figure 64).

On the **iQua™** app, near the bottom of the softener's main dashboard, there is a line labeled "Water Control" with a button that, when pressed, alternates between "Water On" and "Water Off". If you receive an alert indicating continuous water flow, you can use this control to remotely shut off the water.

The system default for triggering a continuous water flow alert is 20 minutes of flow at 0.4 gallons per minute or higher. The time and water flow trigger values may also be adjusted in the "Alerts" section.

To manually operate the motorized water shutoff valve, pull out the round knob on the valve and turn it until the red line in the sight glass matches the desired (open or closed) position. See Figure 65. If you manually operate the valve, the app's "Water Control" feature will be disabled until you reset it by clicking "Yes" next to the "Regain Control?" prompt.

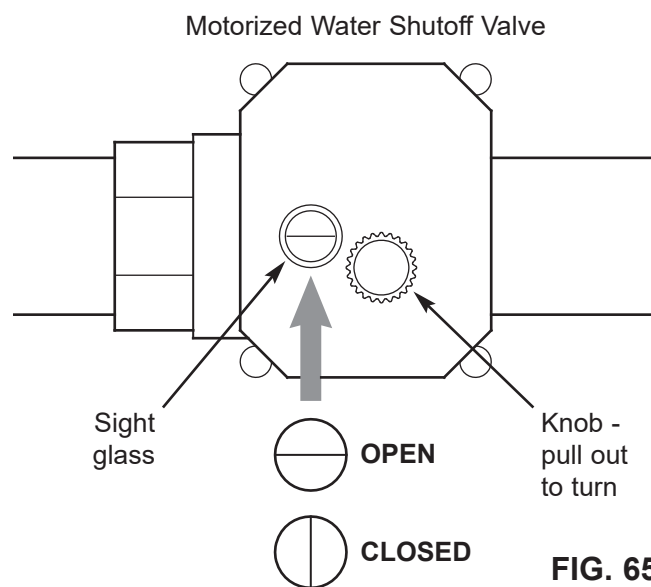
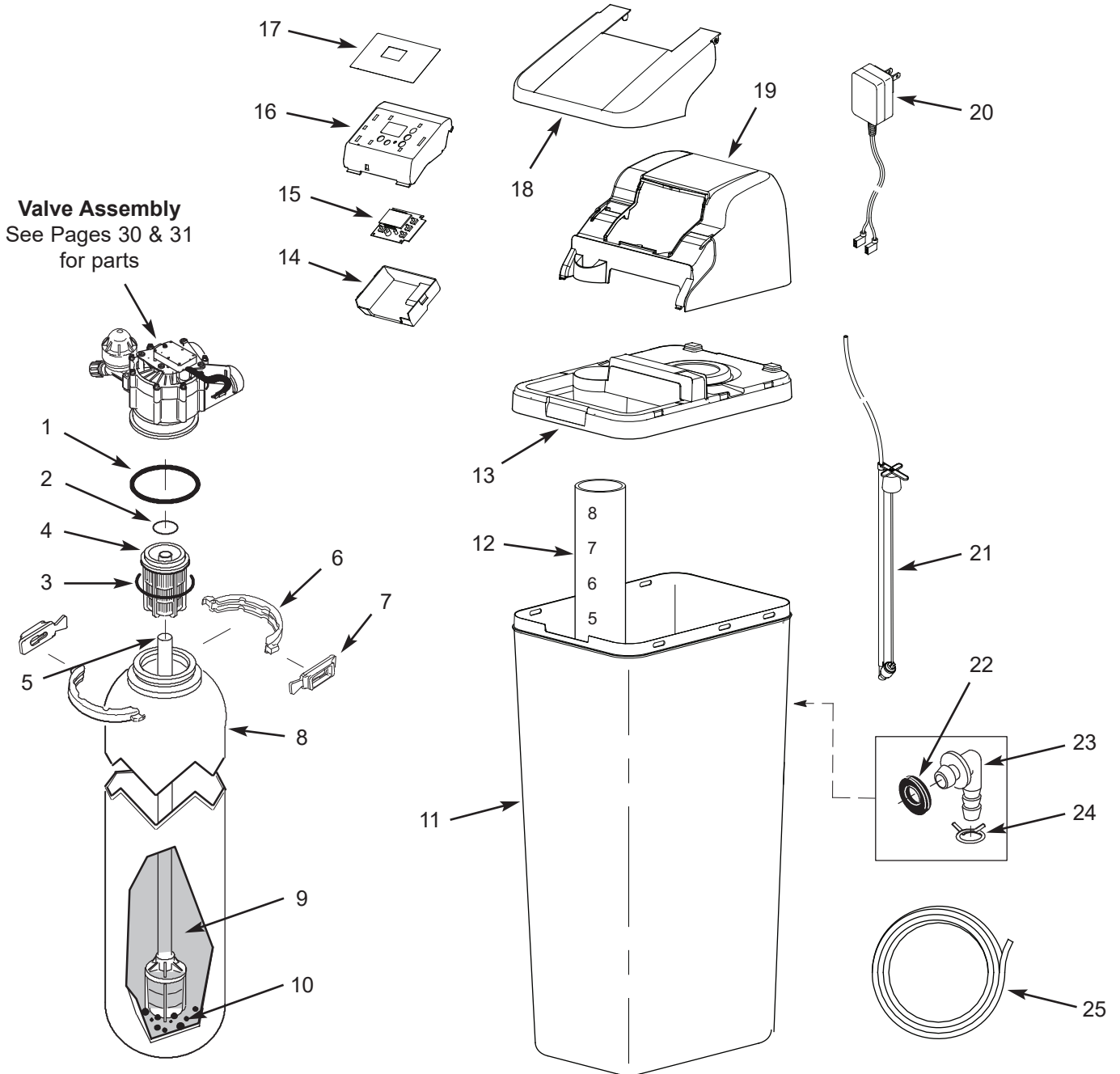

FIG. 65

Softener Exploded View



Softener Parts List

Key No.	Part No.	Description
–	7112963	Distributor O-Ring Kit (includes Key Nos. 1-3)
1	↑	O-Ring, 2-7/8" x 3-1/4"
2	↑	O-Ring, 13/16" x 1-1/16"
3	↑	O-Ring, 2-3/4" x 3"
4	7077870	Top Distributor
5	7327584	Repl. Bottom Distributor
–	7331177	Tank Neck Clamp Kit (includes 2 ea. of Key Nos. 6 & 7)
6	↑	Clamp Section (2 req.)
7	↑	Retainer Clip (2 req.)
8	7247996	Repl. Resin Tank, 10" x 40"
9	0502272	Resin, 1 cu. ft.
	7336834	Activated Carbon, 1 cu. ft.
10	7124415	Gravel
11	7391305	Brine Tank
12	7137824	Brinewell

Key No.	Part No.	Description
13	7391355	Rim
14	7391729	Electronics Enclosure, Rear
15	7389413	Repl. Electronic Control Board (PWA)
16	7391575	Faceplate (order decal below)
17	7393519	Faceplate Decal
18	7391494	Salt Lid (order decal below)
■	7393674	Instruction Decal
19	7391444	Top Cover
20	7351054	Power Supply, 24V DC
21	7381180	Brine Valve Assembly
–	7331258	Overflow Hose Adaptor Kit (includes Key Nos. 22-24)
22	↑	Grommet
23	↑	Adaptor Elbow
24	↑	Hose Clamp
25	7139999	Drain Hose

■ Not illustrated.

To order repair parts, contact us at: info@northstarwater.com

Manufactured and warranted by
Water Channel Partners
1890 Woodlane Drive
Woodbury, MN 55125

Valve Exploded View

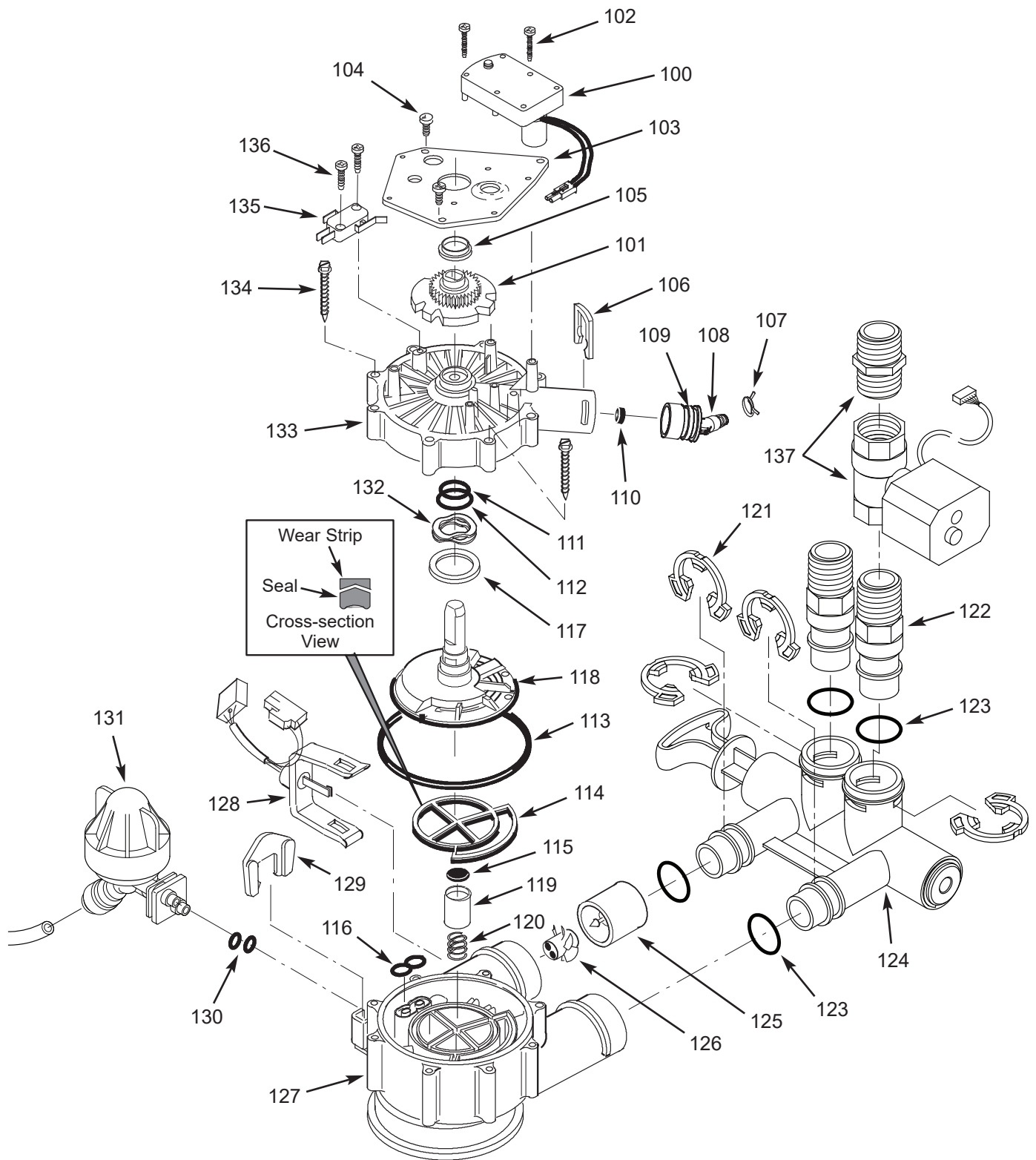

Valve Parts List

Key No.	Part No.	Description
-	7384691	Motor, Cam & Gear Kit, 1" (includes Key Nos. 100-102)
100	↑	Motor
101	↑	Cam & Gear
102	7224087	Screw, #8-32 x 1" (2 req.)
103	7231393	Motor Plate
104	0900857	Screw, #6-20 x 3/8" (3 req.)
105	7171250	Bearing
-	7331169	Drain Hose Adaptor Kit (includes Key Nos. 106-110)
106	↑	Clip, Drain
107	↑	Hose Clamp
108	↑	Drain Hose Adaptor
109	↑	O-Ring, 15/16" x 1-3/16"
110	↑	Flow Plug, 2.0 gpm
-	7185487	Seal Kit (includes Key Nos. 111-116)
111	↑	O-Ring, 5/8" x 13/16"
112	↑	O-Ring, 1-1/8" x 1-1/2"
113	↑	O-Ring, 4-1/2" x 4-7/8"
114	↑	Rotor Seal
115	↑	Seal
116	↑	Seal, Nozzle & Venturi
117	7174313	Bearing, Wave Washer
118	7185500	Rotor & Disc

Key No.	Part No.	Description
-	7342712	Drain Plug Kit, 1" (includes Key Nos. 115, 119 & 120)
119	↑	Plug, Drain Seal
120	↑	Spring
121	7089306	Clip, 1", single (4 req.)
	7336428	Clip, 1", pack of 20
122	7271204	Installation Adaptor, 1", single (2 req.)
	7336614	Installation Adaptor, 1", pack of 10
123	7311127	O-Ring, 1-1/16" x 1-5/16", single (4 req.)
	7336410	O-Ring, 1-1/16" x 1-5/16", pack of 20
124	7214383	Bypass Valve Assembly, 1", including 2 ea. Clips & O-Rings (See Key Nos. 121 & 123)
-	7290931	Turbine & Support Assembly, including 2 O-Rings (See Key No. 123) & 1 ea. of Key Nos. 125 & 126
125	↑	Turbine Support & Shaft
126	↑	Turbine
127	7171145	Valve Body
128	7309811	Wire Harness, Sensor
129	7081201	Retainer, Nozzle & Venturi
130	7342649	O-Ring, 1/4" x 3/8", pack of 2
131	7398705	Nozzle & Venturi Assembly (includes Key Nos. 129 & 130)
143	7175199	Wave Washer
133	7171161	Valve Cover
134	7342681	Screw, #10-14 x 2-5/8", pack of 8
135	7305150	Switch
136	7140738	Screw, #4-24 x 3/4" (2 req.)
137	7388598	Motorized Water Shutoff Valve * with 1" NPT to 1" NPT Pipe Nipple

* Not included with softener.

To order repair parts, contact us at: info@northstarwater.com

Manufactured and warranted by
Water Channel Partners
1890 Woodlane Drive
Woodbury, MN 55125

WATER SOFTENER WARRANTY

Warrantor: Water Channel Partners, 1890 Woodlane Drive, Woodbury, MN 55125

Warrantor guarantees, to the original purchaser when the product is purchased from an authorized dealer, and when installed and maintained in accordance with the instructions, that:

One Year Full Warranty:

- For a period of one (1) year from the date the product is delivered, all parts will be free from defects in materials and workmanship and will perform in accordance with their written specifications.

Limited Warranties:

- For a period of ten (10) years from the date the product is delivered, the salt storage tank and fiberglass resin/mineral tank will not rust, corrode, leak, burst, or in any other manner, fail to perform in accordance with their written specifications.
- For a period of five (5) years from the date the product is delivered, the electronic control board and valve body will be free of defects in materials and workmanship and will perform in accordance with their written specifications.

If, during such respective period, a part proves to be defective, Warrantor will ship a replacement part, directly to your home, without charge. Should a defect or malfunction occur, contact your contractor. If you are unable to contact your contractor, return the part, freight prepaid, directly to the factory at the address below. Enclose with the part a full description of the problem, with your name, full address, date purchased, model and serial numbers, and selling contractor's name and address. We will repair or replace the part and return it to you at no cost if our repair department determines it to be defective under the terms of the warranty.

General Provisions

The above warranties are effective provided the water softener is operated at water pressures not exceeding 125 psi (8.8 kg/cm²), and at water temperatures not exceeding 120°F (49°C); provided further that the water softener is not subject to abuse, misuse, alteration, neglect, freezing, accident or negligence; and provided further that the water softener is not damaged as the result of any force of nature such as, but not limited to, flood, hurricane, tornado or earthquake.

The limited warranty does not cover damage due to: (a) transportation, (b) storage, (c) improper use, (d) failure to follow the product instructions or to perform any preventive maintenance, (e) modifications, (f) unauthorized repair, (g) normal wear and tear, or (h) external causes such as accidents, abuse, or other actions or events beyond Warrantor's reasonable control. Use of aftermarket, used, or non-manufacturer provided parts will void all warranties. Warranty does not cover failures due to improper product installation. Warrantor is excused if failure to perform its warranty obligations is the result of strikes, government regulation, materials shortages, or other circumstances beyond its control.

THERE ARE NO WARRANTIES ON THE WATER SOFTENER BEYOND THOSE SPECIFICALLY DESCRIBED ABOVE. ALL IMPLIED WARRANTIES, INCLUDING ANY IMPLIED WARRANTY OF MERCHANTABILITY OR OF FITNESS FOR A PARTICULAR PURPOSE, ARE DISCLAIMED TO THE EXTENT THEY MIGHT EXTEND BEYOND THE ABOVE PERIODS. THE SOLE OBLIGATION OF WARRANTOR UNDER THESE WARRANTIES IS TO REPLACE OR REPAIR THE COMPONENT OR PART WHICH PROVES TO BE DEFECTIVE WITHIN THE SPECIFIED TIME PERIOD, AND WARRANTOR IS NOT LIABLE FOR CONSEQUENTIAL OR INCIDENTAL DAMAGES. NO DEALER, AGENT, REPRESENTATIVE, OR OTHER PERSON IS AUTHORIZED TO EXTEND OR EXPAND THE WARRANTIES EXPRESSLY DESCRIBED ABOVE.

Some states do not allow the exclusion or limitation of incidental or consequential damages, so the above limitation or exclusion may not apply to you. This warranty gives you specific legal rights, and you may have other rights which vary from state to state. This warranty applies to consumer-owned installations only.

This water softener is manufactured by
Water Channel Partners, 1890 Woodlane Drive, Woodbury, MN 55125
Customer Information Telephone No. 1-800-972-0135